

NEW BUSINESS

ITEM 8.H.

REPORT TO THE BOARD OF DIRECTORS  
BOARD MEETING OF SEPTEMBER 8, 2020  
AGENDA ITEM NO. 8.H.

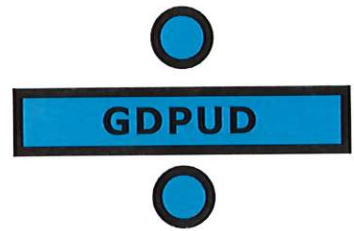

**AGENDA SECTION:** NEW BUSINESS

**SUBJECT:** AWARD CONSTRUCTION CONTRACT TO ERS INDUSTRIAL SERVICES, INC. IN THE AMOUNT OF \$54,640 FOR WALTON LAKE WATER TREATMENT PLANT (WTP) FILTER #3 REHABILITATION

**PREPARED BY:** Elaine Greif, Coastland Civil Engineering

**APPROVED BY:** Darrell Creeks, Operations Manager

---

**BACKGROUND**

The Walton Lake Water Treatment Plant (Walton WTP) produces treated water for distribution within the District. The Walton WTP Filter #3 is showing signs that it needs to be rebuilt.

The filter was originally installed in 1980. Some repairs to the filter are believed to have been completed in past years, but no record of these repairs is available. According to District staff, the filter media was replaced in the late 1990's and all PVC underdrain laterals were replaced. It is also believed that the filter was rebuilt in 2004, which included media replacement, recoating of the filter tank interior, and replacement of the surface wash system. No significant repairs to the filter have been made since the 2004. Filters are a critical component of the treatment process and failure can lead to the inability to produce water suitable for consumption.

The Walton Lake WTP Filter #3 Rehabilitation Project will involve emptying and cleaning the existing filter, repair of broken piping, and replacement of the filter media. Additional work is expected to include repair to the piping connections and repairs to cracked bulkheads.

Completion of this Project supports Fiscal Year 2019/2020 Board of Directors Goal B – "Address Immediate Infrastructure Needs and Begin Long Term Planning," Objective B-1 – "Repair/Replace a few key facilities that are prone to failure".

The project information sheet from the Capital Improvement Plan is included as **Attachment 1**.

On February 11, 2020, the Board approved a professional services agreement with Coastland Civil Engineering to provide project management services to the District for various capital projects and the task order was executed on February 27, 2020.

### **DISCUSSION**

On June 10, 2020, the District released a request for bids for the project. Three (3) potential bidders attended the non-mandatory pre-bid meeting on June 18, 2020 and made a visit to the project location.

The project specifications identify work to be performed in the rehabilitation of the filter to include emptying the filter, replacing damaged piping, installing new filter media.

Due to limited availability of information on past work performed, Coastland performed additional services to research the history of this filter and prepare engineered project specifications for the filter rehabilitation.

On July 1, 2020, the District received two (2) bid proposals with an apparent low bid from Euro Style Management (Euro Style) of \$46,900.00. ERS Industrial Services, Inc. (ERS) provided a bid proposal of \$54,640.00. The bids were opened publicly at the appointed time and location. The bid summary sheet as recorded at the public bid opening is attached as **Attachment 2**. The bids from Euro Style and ERS are provided as **Attachments 3 and 4**.

Table 1 – Bid Summary

Bidder	Bid Amount
Euro Style Management	\$ 46,900.00
ERS Industrial Services, Inc.*	\$ 54,640.00
Engineer's Estimate	\$ 42,000.00

\* Verified Low Bidder

Euro Style Management's bid proposal included all the required forms and staff verified that they have a valid Contractor's license as required by the Project specifications. However, after reviewing the experience and projects submitted by Euro Style, it was apparent that their experience did NOT meet the qualifications required by the contract documents, which require a minimum of five years' experience in the rehabilitation, repair, and maintenance of pressure filters (in Section 6-1.08 Workmanship). None of the listed experience in the submitted bid is for pressure filter work. Coastland notified Euro Style of the concern and requested additional information and project references to give them an

---

opportunity to demonstrate the required experience. Euro Style sent an email (**Attachment 5**) with two more project references for similar work on incomplete projects, and information about their material supplier, Envirotrol. Only one of the additional references was for similar pressure filter tank work. Coastland contacted both of the follow up references, and both references were satisfied with the work performed by Euro Style, but Euro Style still does not have the level of specific water pressure tank experience that is required in the specification.

Staff sought direction from the District's attorney, who provided the following response:

*"Euro Style's bid would be considered nonresponsive under California law, which requires strict compliance with the material terms of the specifications stated in the request for bids. Although the District can waive strict compliance with some terms stated in a bid solicitation, it can only waive compliance with terms that are "immaterial."*

*In this case, the experience requirement would be considered a "material" term as it speaks directly to the qualifications needed to perform this work and the quality expected. If the District waived this experience requirement for Euro Style, it would be providing a benefit to Euro Style, who does not have the requisite experience, over ERS, who does have that experience. Accepting Euro Style's bid would thus give Euro Style a competitive advantage and also create the appearance of favoritism, as District would appear willing to waive an experience requirement for the low bidder that it would not need to waive for the second-lowest bidder, ERS. Should ERS pursue a bid protest on these grounds, it would likely prevail. For the same reasons, Euro Style likely would not prevail in a bid protest action if the District awards the contract to ERS."*

ERS's bid proposal included all the required forms, and Staff verified that they have a valid Contractor's license as required by the Project specifications. ERS also meets and exceeds the experience requirements listed in the specifications. As such, ERS is the only responsive, responsible bidder.

The total price bid by ERS exceeds the engineer's estimate by \$12,640, but is within the District's construction budget of \$70,000 for this project.

The project is planned to be completed by October 31, 2020. Staff recommends that the General Manager have "change order" authority in an amount not to exceed 20% of the contract amount. This will eliminate the need to return to the Board of Directors for minor changes to the project allowing for a timely completion of the project. Due to the nature of this type of project, the extents of damage and wear to the filter interior cannot be identified without taking it offline and emptying

---

it. It is highly probable that there will be some level of extra work needed in order to repair the filter prior to putting it back into service. This extra work includes repairs to the connections between underdrain laterals and the distribution header, repairs to the bulkhead connections to the tank walls, and other incidental welding and recoating.

Because this work cannot be clearly identified or quantified without taking the filter out of service, emptying it, removing the media, and inspecting the interior, the bids do not include repairs to the filter internal piping connections or the tank itself. The contract documents describe the planned extra work and require the contractor to be prepared to perform extra work on a time and materials basis within the allotted timeframe. The cost of this extra work is expected to add approximately 10% to the contract cost. In addition to the planned extra work, it is recommended that the General Manager have the authority to authorize up to 10% in unexpected construction change orders as is standard for most projects.

Once the board takes action to award the contract, Staff will send the Contractor a Notice of Award, and the Contractor will execute the agreement and supply the required performance bond.

### **ANALYSIS**

Since the bid results plus the recommended 20% contingency fall within the amount programmed in the CIP, the District can take one of three alternative actions:

1. Disqualify Euro Style Management and award to ERS (recommended)
2. Waive the specific experience requirement and award to Euro Style Management
3. Reject all bids and provide direction for a re-bid.

### **FISCAL IMPACT**

The Adopted Capital Improvement Plan budget for this Project is \$100,000 from Fund 43 – Capital Reserve. Current budget and projected costs are summarized in the table below.

Table 2 – Project Budget

Phase	CIP Budget	Projected To Complete
Engineering/Project Management	\$ 5,000	\$ 17,000
Construction Management	\$ 25,000	By District staff
Construction (Includes 20% contingency)	\$ 70,000	\$ 65,568
<i>Total</i>	\$100,000	\$ 82,568

**RECOMMENDED ACTION**

Staff recommends the Board of Directors of the Georgetown Divide Public Utility District (GDPUD) adopt the attached Resolution awarding the construction contract to ERS Industrial Services, Inc, authorizing the General Manager to execute a contract with ERS Industrial Services, Inc. in the amount of \$54,640.00 and authorizing the General Manager to approve change orders not to exceed 20% of the contract amount for a total construction authorization amount of \$65,568.00.

**ALTERNATIVES**

Alternatively the Board may (a) award the other scenario; or (b) reject all bids.

**ATTACHMENTS**

1. Adopted Project Information Sheet
2. Bid Results Form
3. Euro Style Management's Bid
4. ERS Industrial Services Inc.'s Bid
5. Eurostyle Management Additional Project References (Submitted via email)
6. Resolution

AGENDA ITEM 8.H.  
ATTACHMENT 1  
PROJECT INFORMATION SHEET

**PROJECT NAME:** Rebuild Filter No.3 at Walton Water Treatment Plant

**PROJECT NUMBER:** TBD

**PROJECT DESCRIPTION:**

Filter number 3 at Walton Water Treatment Plant is showing signs that it needs to be rebuilt. Filters are a critical component of the treatment process and failure can lead to the inability to produce water suitable for consumption.

**LOCATION MAP**

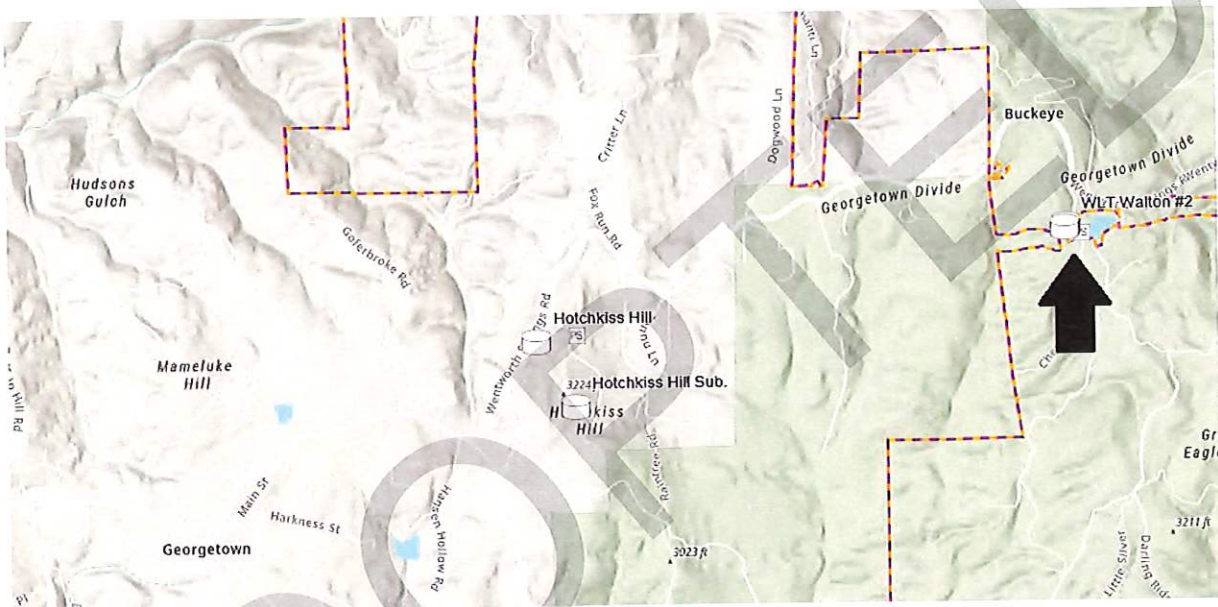

**PHOTOS**





**Project Name:** Rebuild Filter No. 3 at Walton Water Treatment Plant  
**Project Number:** TBD  
**Project Description:** Filter No. 3 needs rebuilding before it fails  
**Funding Sources:**

Sources	Prior Years	FY19/20	FY20/21	FY21/22	FY22/23	FY23/24	Future Years	Total
CABY Grant (9)								0
Capital Reserve (43)		100,000					0	100,000
Prior Reimbursements Received (35)								0
Capital Facility Charge (39)								0
ALT WTP Capital Reserve (24)								0
ALT Zone Fund (40)								0
ALT Tank Replacement Loans & Repair (41)								0
ALT CDS Reserve Connection (42)								0
Grants (EPA)								0
SRF Loan								0
General Fund (10)								0
Other								0
Unfunded								0
<b>Total</b>	0	100,000	0	0	0	0	0	100,000

**Project Cost Estimate:**

Elements	Prior Years	FY19/20	FY20/21	FY21/22	FY22/23	FY23/24	Future Years	Total
Preliminary Engineering (7020)								0
Environmental (7021)								0
Land/ROW Acquisition (7022)								0
Construction Engineering (7024)		25,000						25,000
Construction Contract (7023)		70,000						70,000
Other CIP Costs (7025)		5,000						5,000
Other - TBD								0
<b>Total</b>	0	100,000	0	0	0	0	0	100,000

ADOPTED

AGENDA ITEM 8.H.

ATTACHMENT 2

BID RESULTS FORM



AGENDA ITEM 8.H.

ATTACHMENT 3

EURO STYLE BID

1.2 BID

**Walton Water Treatment Plant Filter No. 3 Rehabilitation**

NAME OF BIDDER: Euro Style Management

STREET ADDRESS: 3600 Madison Ave #51B

CITY, STATE, ZIP: North Highlands CA 95660

PHONE NO. (916) 331-4858 FAX NO. (916) 880-5504

CONTRACTOR LICENSE TYPE & NO.:  
841418 #, B, C-33

The work for which this proposal is submitted is for construction in conformance with the Special Provisions (including the payment of not less than the prevailing wage rates), the project plans, if any, described below, including any addenda thereto, the contract annexed hereto, and also in conformance with the Georgetown Divide Public Utility District specifications.

The Special Provisions for the Work to be done are dated **June 2020**. and are entitled:

**Walton Lake Water Treatment Plant Filter No. 3 Rehabilitation Project**

Bids are to be submitted for the entire work. The amount of the bid for comparison will be the total of all items.

The Bidder shall set forth, for each unit basis item of work, a unit price and a total for the item, and for each lump sum item a total for the item, all in clearly legible figures in the respective spaces provided for that purpose. In the case of unit basis items, the amount set forth under the "Item Total" column shall be the product of the unit price bid and the estimated quantity for the item.

In the case of a discrepancy between the unit price and the total set forth for a unit basis item, the unit price shall prevail, except as provided in (a) or (b), as follows:

- (a) If the amount set forth as a unit price is unreadable or otherwise unclear, or is omitted, or is the same as the amount as the entry in the item total column, then the amount set forth in the item total column for the item shall prevail and shall be divided by the estimated quantity for the item and the price thus obtained shall be the unit price;
- (b) (Decimal Errors) If the product of the entered unit price and the estimated quantity is exactly off by a factor of ten, one hundred, etc. or one-tenth, one-hundredth, etc. from the

entered total, the discrepancy will be resolved by mutual resolution between the two parties.

If both the unit price and the item total are unreadable or otherwise unclear, or are omitted, the bid may be deemed irregular. Likewise, if the item total for a lump sum item is unreadable or otherwise unclear, or is omitted, the bid may be deemed irregular unless the project being bid has only a single item and a clear, readable total bid is provided.

Symbols such as commas and dollar signs will be ignored and have no mathematical significance in establishing any unit price or item total or lump sums. Written unit prices, item totals and lump sums will be interpreted according to the number of digits and, if applicable, decimal placement. Cents symbols also have no significance in establishing any unit price or item total since all figures are assumed to be expressed in dollars and or decimal fractions of a dollar. Bids on lump sum items shall be item totals only; if any unit price for a lump sum item is included in a bid and it differs from the item total, the item total shall prevail.

The foregoing provisions for the resolution of specific irregularities cannot be so comprehensive as to cover every omission, inconsistency, error or other irregularity which may occur in a bid. Any situation not specifically provided for will be determined in the discretion of the Georgetown Divide Public Utility District, and that discretion will be exercised in the manner deemed by the Georgetown Divide Public Utility District to best protect the public interest in the prompt and economical completion of the work. The decision of the Georgetown Divide Public Utility District respecting the amount of a bid, or the existence or treatment of an irregularity in a bid, shall be final.

If this proposal shall be accepted and the undersigned shall fail to enter into the contract and furnish the bond(s) in the sums required by the State Contract Act, with surety satisfactory to the Georgetown Divide Public Utility District, and the insurance certificates within ten (10) days, not including Saturdays, Sundays, and legal holidays, after the Bidder has received notice from the Georgetown Divide Public Utility District that the contract has been awarded, the Georgetown Divide Public Utility District may, at its option, determine that the Bidder has abandoned the contract, and thereupon this proposal and the acceptance thereof shall be null and void and the forfeiture of the security accompanying this proposal shall operate and the same shall be the property of the Georgetown Divide Public Utility District.

When submitting its bid, the Bidder shall include security in the form of cash; cashier's check made payable to the District; a certified check made payable to the District or a bidder's bond executed by an admitted surety insurer, made payable to the District. The amount of security shall be 10 percent of the amount bid. Should the Bidder be awarded the contract, but fail to execute the contract, its security shall be forfeited to the District.

The Bidder has familiarized itself with the nature and extents of the Contract Documents, the Work, the site, the locality where the Work is to be performed, the legal requirements (federal, state and local laws, ordinances, rules, and regulations), and the conditions affecting cost,

progress or performance of the Work, and has made such independent investigations as Bidder deems necessary.

The undersigned, as bidder, declares that the only persons or parties interested in this proposal as principals are those named herein; that this proposal is made without collusion with any other person, firm, or corporation; that he has carefully examined the plans therein referred to; and the contractor proposes, and agrees if this proposal is accepted, that they will contract with the Georgetown Divide Public Utility District, in the form of the copy of the contract annexed hereto, to provide all necessary machinery, tools, apparatus and other means of construction, and to do all the work and furnish all the materials specified in the contract, in the manner and time therein prescribed, and according to the requirements of the District as therein set forth, and that the contractor will take in full payment therefor the following prices, to wit:

### 1.3 BID SCHEDULE

#### Walton Water Treatment Plant Filter #3 Rehabilitation Project

Item No.	Items	Estimated Quantity	Unit of Measure	Price per Unit	Total
1	Mobilization, Insurance, Bonds	1	LS	--	\$4,500
2	Drain, empty, clean, and prepare existing tank	1	LS	--	\$12,700
3	Identify and Replace Underdrain Laterals	20	EA	\$85.00	\$1,700
4	Supply and Install New Media	1	LS	--	\$26,400
5	Startup and Testing	1	LS	--	\$1,600
Total Bid Amount:					\$46,900.00

Forty Six Thousand Nine Hundred Dollars & No Cents.

**Total Amount in Words**

Contractor Company Name: Euro Style Management

#### 1.4 Designation of Subcontractors

In compliance with Public Contract Code section 4100 et seq. each bidder shall set forth below the(a) name and location of the mill, shop, or office of each subcontractor who will perform work or labor or render service to the Contractor in or about the construction of the work or improvement to be performed under these specifications in excess of one-half of 1% of the Contractor's total bid, (b) description of the type of work to be performed by each such subcontractor, and (c) portion of the work (expressed in dollar amount) that will be performed by each such subcontractor.

Subletting or subcontracting of any portion of the work in excess of one-half of 1% of the Contractor's total bid as to which no subcontractor was designated in the original bid shall only be permitted in cases of public emergency or necessity, and then only after a finding reduced to writing as a public record of the Agency setting forth the facts constituting the emergency or necessity.

Subcontractor (name and location)	Description of Subcontractor Work	Estimated Portion of Work (in%)
	None	



#### 4.5 Bid Bond

KNOW ALL MEN BY THESE PRESENTS, THAT WE, THE UNDERSIGNED

Euro Style Management, Contractor as Principal; and The Ohio Casualty Insurance Company

, as Surety, are hereby held and bound unto Georgetown Divide Public Utility District, hereinafter called the District, in the sum of \$ 10.0% of bid amount which sum is equal to at least ten percent of the total amount of the Bid, payment of which sum, well and to be made, we hereby jointly and severally bind ourselves, our heirs, executors, administrators, successors, and assigns.

The condition of the above obligation is such that whereas the Principal has submitted to the District a certain Bid, attached hereto and hereby made a part hereof, to enter into a Contract in writing, for the construction of the following public works project;

**Walton Lake Water Treatment Plant Filter #3 Rehabilitation Project**

NOW, THEREFORE,

(a) If the Bid is rejected, or in the alternate,

(b) If the Bid is accepted and the Principal shall sign and deliver a Contract, in the form of the Contract attached hereto and shall execute and deliver Performance and Payment Bonds in the forms attached hereto and shall deliver proof of insurance (all completed in accordance with the Contract Documents), and shall in all other respects perform the agreement created by the acceptance of the Bid;

Then, this obligation shall be void, otherwise the same shall remain in force and effect; it being expressly understood and agreed that the liability of the Surety for any and all default of the Principal hereunder shall be the amount of this obligation as herein stated.

The Surety, for value received, hereby stipulates and agrees that the obligations of said Surety and its bond shall be in no way impaired or affected by any extension of the time within which the District may accept such Bid, and said Surety does hereby waive notice of any such extension.

IN WITNESS THEREOF, the above-bounded parties have executed this instrument under their several seals this 26th day of June 2020, the name and corporate seal of each corporate party being hereto affixed and those presents duly signed by its undersigned representative, pursuant to authority of its governing body.

Euro Style Management

(Contractor as Principal)

By:

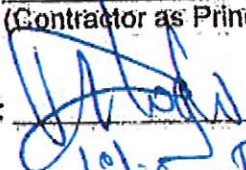
  
Lilia Bugryel

[Name]

CFO

[Title]

(Seal)

The Ohio Casualty Insurance Company

(Surety)

By:

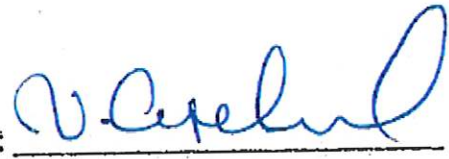

Vanessa Copeland

[Name]

Attorney-in-fact

[Title]

(Seal)

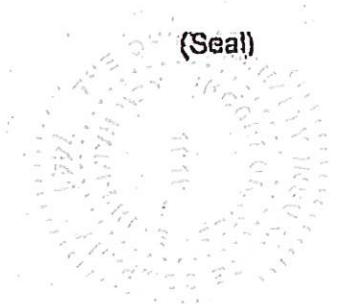

**CALIFORNIA ALL-PURPOSE ACKNOWLEDGMENT**

**CIVIL CODE 1189**

A notary public or other officer completing this certificate verifies only the identity of the individual who signed the document to which this certificate is attached and not the truthfulness, accuracy, or validity of that document.

State of California )

County of Orange )

On 6/26/20 before me, Natassia Kirk-Smith, Notary Public,

personally appeared Vanessa Copeland  
Name(s) of Signer(s)

who proved to me on the basis of satisfactory evidence to be the person(s) whose name(s) is/are subscribed to the within instrument and acknowledged to me that he/she/they executed the same in his/her/their authorized capacity(ies), and that by his/her/their signature(s) on the instrument the person(s), or the entity upon behalf of which the person(s) acted, executed the instrument.

I certify under PENALTY OF PERJURY under the laws of the State of California that the foregoing paragraph is true and correct.

WITNESS my hand and official seal.  
Signature: Natassia Smith  
Signature of Notary Public



Place Notary Seal Above

**OPTIONAL**

Though the information below is not required by law, it may prove valuable to persons relying on the document and could present fraudulent and reattachment of this form to another document.

**Description of Attached Document**

Type or Title of Document: \_\_\_\_\_

Document Date: \_\_\_\_\_ Number of Pages: \_\_\_\_\_

Signer(s) Other Than Named Above: \_\_\_\_\_

**Capacity(ies) Claimed by Signer(s)**

Signer's Name: Vanessa Copeland

- Individual
- Corporate Officer - Title(s): \_\_\_\_\_
- Partner:  Limited  General
- Attorney in Fact
- Trustee
- Guardian or Conservator
- Other: \_\_\_\_\_

Signer Is Representing: \_\_\_\_\_

**Capacity(ies) Claimed by Signer(s)**

Signer's Name: \_\_\_\_\_

- Individual
- Corporate Officer - Title(s): \_\_\_\_\_
- Partner:  Limited  General
- Attorney in Fact
- Trustee
- Guardian or Conservator
- Other: \_\_\_\_\_

Signer Is Representing: \_\_\_\_\_



This Power of Attorney limits the acts of those named herein, and they have no authority to bind the Company except in the manner and to the extent herein stated.

Liberty Mutual Insurance Company
The Ohio Casualty Insurance Company
West American Insurance Company

Certificate No 8200195

POWER OF ATTORNEY

KNOWN ALL PERSONS BY THESE PRESENTS: That The Ohio Casually Insurance Company is a corporation duly organized under the laws of the State of New Hampshire, that Liberty Mutual Insurance Company is a corporation duly organized under the laws of the State of Massachusetts, and West American Insurance Company is a corporation duly organized under the laws of the State of Indiana (herein collectively called the "Companies"), pursuant to and by authority herein set forth, does hereby name, constitute and appoint, Kevin Cathcart, Vanessa Copeland, Eric Lowey, Mark Richardson

all of the city of Costa Mesa state of CA each individually if there be more than one named, its true and lawful attorney-in-fact to make, execute, seal, acknowledge and deliver, for and on its behalf as surety and as its act and deed, any and all undertakings, bonds, recognizances and other surety obligations, in pursuance of these presents and shall be as binding upon the Companies as if they have been duly signed by the president and attested by the secretary of the Companies in their own proper persons.

IN WITNESS WHEREOF, this Power of Attorney has been subscribed by an authorized officer or official of the Companies and the corporate seals of the Companies have been affixed thereto this 28th day of December, 2018.

Liberty Mutual Insurance Company
The Ohio Casualty Insurance Company
West American Insurance Company

By: David M. Carey, Assistant Secretary



State of PENNSYLVANIA
County of MONTGOMERY ss

On this 28th day of December, 2018 before me personally appeared David M. Carey, who acknowledged himself to be the Assistant Secretary of Liberty Mutual Insurance Company, The Ohio Casualty Company, and West American Insurance Company, and that he, as such, being authorized so to do, execute the foregoing instrument for the purposes therein contained by signing on behalf of the corporations by himself as a duly authorized officer.

IN WITNESS WHEREOF, I have hereunto subscribed my name and affixed my notarial seal at King of Prussia, Pennsylvania, on the day and year first above written.



COMMONWEALTH OF PENNSYLVANIA
Notarial Seal
Teresa Pastella, Notary Public
Upper Merion Twp., Montgomery County
My Commission Expires March 28 2021
Member, Pennsylvania Association of Notaries

By: Teresa Pastella, Notary Public

Not valid for mortgage, note, loan, letter of credit, currency rate, interest rate or residual value guarantees.

To confirm the validity of this Power of Attorney call 1-610-832-8240 between 9:00 am and 4:30 pm EST on any business day.

This Power of Attorney is made and executed pursuant to and by authority of the following By-laws and Authorizations of The Ohio Casualty Insurance Company, Liberty Mutual Insurance Company, and West American Insurance Company which resolutions are now in full force and effect reading as follows:

ARTICLE IV - OFFICERS: Section 12. Power of Attorney

Any officer or other official of the Corporation authorized for that purpose in writing by the Chairman or the President, and subject to such limitation as the Chairman or the President may prescribe, shall appoint such attorneys-in-fact, as may be necessary to act in behalf of the Corporation to make, execute, seal, acknowledge and deliver as surety any and all undertakings, bonds, recognizances and other surety obligations. Such attorneys-in-fact, subject to the limitations set forth in their respective powers of attorney, shall have full power to bind the Corporation by their signature and execution of any such instruments and to attach thereto the seal of the Corporation. When so executed, such instruments shall be as binding as if signed by the President and attested to by the Secretary. Any power or authority granted to any representative or attorney-in-fact under the provisions of this article may be revoked at any time by the Board, the Chairman, the President or by the officer or officers granting such power or authority.

ARTICLE XIII - Execution of Contracts: Section 5. Surety Bonds and Undertakings.

Any officer of the Company authorized for that purpose in writing by the chairman or the president, and subject to such limitations as the chairman or the president may prescribe, shall appoint such attorneys-in-fact, as may be necessary to act in behalf of the Company to make, execute, seal, acknowledge and deliver as surety any and all undertakings, bonds, recognizances and other surety obligations. Such attorneys in fact subject to the limitations set forth in their respective powers of attorney, shall have full power to bind the Company by their signature and execution of any such instruments and to attach thereto the seal of the Company. When so executed such instruments shall be as binding as if signed by the president and attested by the secretary.

Certificate of Designation - The President of the Company, acting pursuant to the Bylaws of the Company, authorizes David M. Carey, Assistant Secretary to appoint such attorneys-in-fact as may be necessary to act on behalf of the Company to make, execute, seal, acknowledge and deliver as surety any and all undertakings, bonds, recognizances and other surety obligations.

Authorization - By unanimous consent of the Company's Board of Directors, the Company consents that facsimile or mechanically reproduced signature of any assistant secretary of the Company, wherever appearing upon a certified copy of any power of attorney issued by the Company in connection with surety bonds, shall be valid and binding upon the Company with the same force and effect as though manually affixed.

I, Renee C. Llewellyn, the undersigned, Assistant Secretary, The Ohio Casualty Insurance Company, Liberty Mutual Insurance Company, and West American Insurance Company do hereby certify that the original power of attorney of which the foregoing is a full, true and correct copy of the Power of Attorney executed by said Companies, is in full force and effect and has not been revoked.

IN TESTIMONY WHEREOF, I have hereunto set my hand and affixed the seals of said Companies this 26th day of June, 2020.



By: Renee C. Llewellyn, Assistant Secretary

**1.6 Experience Qualifications**

The Bidder has been engaged in the contracting business, under the present business name for 16 years. Experience in work of a nature similar to that covered in the Bid extends over a period of 11 years.

The Bidder, as a contractor, has never failed to satisfactorily complete a contract awarded to it, except as follows:

None

---

---

---

---

The following contracts have been satisfactorily completed in the last three years for the persons, firm or entity indicated: (Bidder may provide additional experience statements).

<u>Year</u>	<u>Owner</u>	<u>Type of Work</u>	<u>Contract Amount</u>
-------------	--------------	---------------------	------------------------

Please see attached reference

---

---

---

---

The following is a list of plant and equipment owned by the Bidder, which is definitely available for use on the proposed work as required. (Bidder may provide additional list of plant and equipment available).

<u>Quantity</u>	<u>Name, Type and Capacity</u>	<u>Condition</u>	<u>Location</u>
<u>1</u>	<u>Blast pot</u>	<u>Good</u>	<u>Sacto</u>
<u> </u>	<u> </u>	<u> </u>	<u> </u>
<u> </u>	<u> </u>	<u> </u>	<u> </u>
<u> </u>	<u> </u>	<u> </u>	<u> </u>
<u> </u>	<u> </u>	<u> </u>	<u> </u>
<u> </u>	<u> </u>	<u> </u>	<u> </u>
<u> </u>	<u> </u>	<u> </u>	<u> </u>
<u> </u>	<u> </u>	<u> </u>	<u> </u>
<u> </u>	<u> </u>	<u> </u>	<u> </u>
<u> </u>	<u> </u>	<u> </u>	<u> </u>

\_\_\_\_\_  
\_\_\_\_\_

Executed on 6/29/, 2020, at Sacramento, CA.

I declare under penalty of perjury under the laws of the State of California that the foregoing is true and correct.

BIDDER

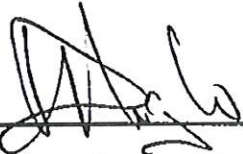
[Authorized signature]   
[Company/firm name] Euro Style Management  
[Name] Lilia Bugriyev  
[Title] CEO

# Euro Style Management, Inc

3600 Madison Avenue #51B N. Highlands, CA 95660

Office: 916-331-4858, Fax 916-880-5504

Email Address: [support@esm.cc](mailto:support@esm.cc)

License No. 841418 A, B, C33, ASB

QP1 & QP2 Certified

DIR # 1000008873

## Firm Description

Euro Style Management incorporated in December 2003. ESM has industrial experience and knowledge, currently holds A, B, C-33 Licenses also holds SSPC-QP1 and QP-2 certifications. In our references listed below please review our experience.

## Reference

Owner: Central Contra Costa Sanitary District  
**Treatment Plant Protective Coatings, Phase 4**  
Project Inspector: Rick Jones 925-381-0838  
General Contractor: Euro Style Management  
Completed: 2012 Contract Price \$ 551,939.16

Owner: City of Stockton Municipal Utilities Department  
**RWCF and Headworks Repairs Project**  
Project Manager: Bobby Mamsang 209-937-8717  
General Contractor: Euro Style Management  
Completed: 2011 Contract price \$ 299,000

Owner: Central Marin Sanitation Agency  
**Industrial Coatings- Primary Clarifiers**  
Project Manager: Ken Katen 415-459-1455  
General Contractor: Euro Style Management  
Completed date of clarifier# 1 9/17/12 Completion  
Date on clarifier# 2 10/15/12 Contract Price \$ 90,597.62

Owner: City of Newark  
**Natorium Ceiling & Mechanical Repairs Silliman Activity Center**  
Project manager: Dwight Ortman 650-364-8141  
GC: Beals Martin  
Completed: 2013 Contract Price \$ 1,860,020.70

*Specializing in Construction and Restoration*



June 24, 2020

Page 2

Owner: Sacramento Regional County sanitation District  
**Digester No5 Gas Seal Repair**  
Building Inspector: les Campbell (916) 591-0680  
General Contractor: Euro Style Management  
Completed: 2013 Contract Price \$ 230,832.28

Owner: City of Sunnyvale  
**Air Flotation Tank 1&4 Improvements Project**  
General Contractor: Anderson Pacific Engineering  
Project Manager: Mike Gossett 408-970-9900  
Completed: 2013 Contract Price \$ 428,429.86

Owner: City of San Jose  
**Coating Rehabilitation of 5 Clarifier Tanks**  
GC: Euro Style Management Inc  
Project Manager: Paul Blach 408-945-5361  
Completed: 2014 Contract Price \$ 613,248.60

Owner: City of Morgan Hill  
**Llagas Reservoir Re-Coating & Structural Upgrade Project**  
Project Manager: Mario Iglesias 408-776-7333  
GC: Euro Style Management Inc  
Completed: 2013 Contract Price \$ 191,500

Owner: Sacramento Regional County sanitation District  
**Digester # 9 Re-Coating Project**  
Project manager: Les Campbell 916-875-9214  
GC: Euro Style Management Inc  
Completed: 2014 Contract Price \$ 237,000

Owner: California Department of Transportation  
**Heat Straighten Bridge Girder Contract # 10-0W7204**  
Project manager: Dan Dilsaver 707-249-0954  
GC: American Civil Constructors West Coast Inc  
Completed: 2014 Contract Price \$ 105,910.38

Owner: California Department of transportation  
**Bridge Deck maintenance Project # 03-4M5004**  
Project Manager: Joe McLoughlin 909-944-1037  
GC: J.McLoughlin Engineering Co.  
Completed: 2014 Contract Price \$ 324,630

Owner: Sacramento Regional County Sanitation District  
**Digester #8 Rehabilitation Project**  
project Manager: Guillermo Robles PE 916-875-9500  
GC: TNT Industrial Contractor  
Completed: 2015 Contract Price \$ 423,266.35

June 24, 2020

Page 3

Owner: Redwood City  
**Water Tank & Pump Stations Seismic Improvements**  
Project manager: Ryan Miller 408-970-9900  
GC: Anderson pacific Engineering Inc  
Completed: 2015 Contract Price \$ 122,000

Owner: City of Pleasanton  
**Bridge Preventive maintenance Program for 7 Various Bridges**  
Inspector: Vinny Ngo 925-351-5027  
GC: ETIC Engineering Inc.  
Completed: 2015 Contract Price \$ 218,500

Owner: Caltrans  
**Treat Bridge Deck & Replace Joint Seal**  
Project Manager: Robert Druckenmiller 951-352-4300  
GC: Western Structures Inc.  
Completed: 2015 Contract Price \$ 33,900

Owner: City of Rocklin  
**Sunset Boulevard/UPRR Repair & Paint Project**  
Project manager: Zach Bosh 916-625-5500  
GC: Euro Style Management Inc  
Completed: 2015 Contract Price \$ 424,321.17

Owner: Sacramento County Regional Sanitation District  
**Digester 10 and 11 Rehabilitation Project**  
Project Manager: Guillermo Robles PE 916-875-9014  
GC: Manito Construction  
Completed: 2017 Contract Price \$ 1,292,168.38 ( Coating work)

Owner: Soquel Creek Water District  
**Cornwell Tank Recoating Project**  
Project Manager: Taj Dufour 831-475-8500  
GC: Euro Style Management  
Completed: 2018 Contract Price \$ 429,950.00

Owner: Fairfield – Suisun Sewer District  
**2018 Coatings Project**  
Project Manager: Ron Hipkiss 707-429-8930  
GC: Euro Style Management  
Completed: 2019 Contract Price \$ 644,000.00

Owner: Stinson Beach County Water District  
**Laurel Tank Coating and Repairs Project**  
Project Manager: Allan Richards PE 415-868-1333  
GC: Euro Style Management  
Completed: 2019 Contract price \$ 481,672.69

June 24, 2020

Page 4

Owner: City of San Jose Regional Wastewater Facility

**Coating Rehabilitation Services 4 Clarifier Tanks**

Project Manager: Dale Bone 408-406-3096

GC: Euro Style Management

Completed: 2019 Contract Price \$ 652,000.00

Owner: Sacramento Regional County Sanitation District

**Primary Deck Rehabilitation Project**

Project Manager: Guillermo Robles PE 916-875-9014

GC: TPA Construction

Completed: 2019 Contract Price \$ 350,000.00

Owner: Sacramento Regional County Sanitation District

**Digester 5,6,7 Rehabilitation Project**

Project Manager: Guillermo Robles PE 916-875-9014

GC: TNT Industrial Contractor

Completed: 2019 Contract Price \$ 3,702,729.43 (Coating work)

Owner: Sacramento Regional County Sanitation District

**Water Reclamation Tank Coating Project**

Project Manager: Andrew Frankel PE 916-875-9014

GC: Euro Style Management

Completed: 6/2020 Contract price \$ 898,026.91

Owner: Scotts Valley Water District

**Sequoia Reservoir-Interior Recoating**

Project Manager: David McNair PE 831-438-2363

GC: Euro Style Management

Completed: 6/2020 Contract Price \$ 740,088.08

Respectfully,

Lilia Bugriyev  
CFO

---

Contractor's signature

## 1.7 EQUAL EMPLOYMENT CLAUSE

(40 CFR 60-8.4(b) and EO 11246 & 11375 & 12086)

The Federal Equal Employment Opportunity Law requires that all Government contracting agencies shall include in every Government contract hereafter entered into the following provisions:

During the performance of this contract, the contractor agrees as follows:

(1) The contractor will not discriminate against any employee or applicant for employment because of race, color, religion, sex, or national origin. The contractor will take affirmative action to ensure that applicants are employed, and that employees are treated during employment, without regard to their race, color, religion, sex or national origin. Such action shall include, but not be limited to the following: employment, upgrading, demotion, or transfer; recruitment or recruitment advertising; layoff or termination; rates of pay or other forms of compensation; and selection for training, including apprenticeship. The contractor agrees to post in conspicuous places, available to employees and applicants for employment, notices to be provided by the contracting officer setting forth the provisions of this nondiscrimination clause. The required notice follows this section.

(2) The contractor will, in all solicitations or advertisements for employees placed by or on behalf of the contractor, state that all qualified applicants will receive consideration for employment without regard to race, color, religion, sex or national origin.

(3) The contractor will send to each labor union or representative of workers with which he has a collective bargaining agreement or other contract or understanding, a notice, to be provided by the agency contracting officer, advising the labor union or workers' representative of the contractor's commitments under Section 202 of Executive Order No. 11246 of September 24, 1965, and shall post copies of the notice in conspicuous places available to employees and applicants for employment. The required notice follows this section.

(4) The contractor will comply with all provisions of Executive Order No. 11246 of Sept. 24, 1965, and of the rules, regulations, and relevant orders of the Secretary of Labor.

(5) The contractor will furnish all information and reports required by Executive Order No. 11246 of September 24, 1965, and by the rules, regulations, and orders of the Secretary of Labor, or pursuant thereto, and will permit access to his books, records, and accounts by the contracting agency and the Secretary of Labor for purposes of investigation to ascertain compliance with such rules, regulations, and orders.

(6) In the event of the contractor's noncompliance with the nondiscrimination clauses of this contract or with any of such rules, regulations, or orders, this contract may be cancelled, terminated or suspended in whole or in part and the contractor may be

declared ineligible for further Government contracts in accordance with procedures authorized in Executive Order No. 11246 of Sept. 24, 1965, and such other sanctions may be imposed and remedies invoked as provided in Executive Order No. 11246 of September 24, 1965, or by rule, regulation, or order of the Secretary of Labor, or as otherwise provided by law.

(7) The contractor will include the provisions of paragraphs (1) through (7) in every subcontract or purchase order unless exempted by rules, regulations, or orders of the Secretary of Labor issued pursuant to Section 204 of Executive Order No. 11246 of September 24, 1965, so that such provisions will be binding upon each subcontractor or vendor. The contractor will take such action with respect to any subcontract or purchase order as may be directed by the Secretary of Labor as a means of enforcing such provisions including sanctions for noncompliance: Provided, however, that in the event the contractor becomes involved in, or is threatened with, litigation with a subcontractor or vendor as a result of such direction, the contractor may request the United States to enter into such litigation to protect the interests of the United States."

**1.8 CERTIFICATION REGARDING DEBARMENT, SUSPENSION, AND OTHER RESPONSIBILITY MATTERS**

Name of Company/Entity: Euro Style Management

The prospective participant certifies to the best of its knowledge and belief that it and its principals:

- (a) Are not presently debarred, suspended, proposed for debarment, declared ineligible, or voluntarily excluded from covered transactions by a government entity (Federal, State, or local).
- (b) Have not within a three year period preceding this proposal been convicted of or had a civil judgment rendered against them for commission of fraud or a criminal offense in connection with obtaining, attempting to obtain, or performing a public (Federal, State, or local) transaction or contract under a public transaction; violation of Federal or State antitrust statutes or commission of embezzlement, theft, forgery, bribery, falsification or destruction of records, making false statements, or receiving stolen property;
- (c) Are not presently indicted for or otherwise criminally or civilly charged by a government entity (Federal, State, or local) with commission of any of the offenses enumerated in paragraphs (a) and (b) of this certification; and
- (d) Have not within a three-year period preceding this application/proposal had one or more public transactions (Federal, State or local) terminated for cause or default. I understand that a false statement on this certification may be grounds for rejection of this proposal or termination of the award. In addition, under 18 USC Section 1001, a false statement may result in a fine of up to \$ 10,000 or imprisonment for up to five (5) years, or both.

Lilia Bugaryev CFO  
Name and Title of Authorized Representative (Typed/printed)

[Signature]  
Signature of Authorized Representative

6/29/20  
Date

I am unable to certify to the above statements. My explanation is below.



**1.9 NON COLLUSION AFFIDAVIT\***

[TO BE EXECUTED BY BIDDER AND SUBMITTED WITH BID]

State of California County of Sacramento,  
Lilia Bugriyev, being first duly sworn, deposes and says that he or  
she is CFO of Euro Style Management, the  
party making the foregoing bid, that the bid is not made in the interest of, or on behalf  
of, any undisclosed person, partnership, company, association, organization, or  
corporation; that the bid is genuine and not collusive or sham; that the bidder has not  
directly or indirectly colluded, conspired, connived, or agreed with any bidder or anyone  
else to put in a sham bid, or that anyone shall refrain from bidding; that the bidder has  
not in any manner, directly or indirectly, sought by agreement, communication, or  
conference, with anyone to fix the bid price of the bidder or any other bidder, or to fix  
any overhead, profit, or cost element of the bid price, or of that of any other bidder, or to  
secure any advantage against the public body awarding the contract of anyone  
interested in the proposed contract; that all statements contained in the bid are true;  
and, further, that the bidder has not, directly or indirectly, submitted his or her bid price  
or any breakdown thereof, or the contents thereof, or divulged information or data  
relative thereto, or paid, and will not pay, any fee to any corporation, partnership,  
company association, organization, bid depository, or to any member or agent thereof  
the effectuate a collusive or sham bid.

By: [Signature]

personally known to me OR proved to me on the basis of satisfactory evidence to be the  
person(s) whose name(s) is/are subscribed to the within instrument and acknowledged  
to me that he/she/they executed the same in his/her/their authorized capacity(ies), and  
that by his/her/their signatures(s) on the instrument the person(s), or entity upon behalf  
of which the person(s) acted, executed the instrument.

Subscribed and sworn to before me on 30<sup>th</sup> JUNE, 2020

[Signature]  
\_\_\_\_\_  
(Notary Public)

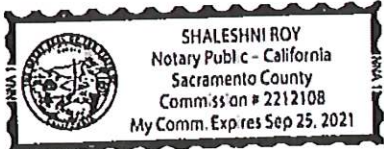

\*Note: Public Contracts Code 7106 requires this non-collusion affidavit be submitted  
with a bid for any public works contract of a public entity.



**[RESERVED FOR NOTARY]**

**1.10 NONDISCRIMINATION CLAUSE**

1. During the performance of this contract, contractor and its subcontractors shall not unlawfully discriminate against any employee or applicant for employment because of race, religion, color, national origin, ancestry, physical handicap, medical condition, marital status, age (over 40) or sex. Contractors and subcontractors shall insure that the evaluation and treatment of their employees and applicants for employment are free of such discrimination. Contractors and subcontractors shall comply with the provisions of the Fair Employment and Housing Act (Government Code Section 12900 et seq.) and the applicable regulations promulgated thereunder (California Administrative Code, Title 2, Section 7285.0 et seq.). The applicable regulations of the Fair Employment and Housing Commission implementing Government Code, Section 12900, set forth in Chapter 5 of Division 4 of Title 2 or the California Administrative Code are incorporated into this contract by reference and made a part hereof as if set forth in full. Contractor and its subcontractor shall give written notice of their obligations under this clause to labor organizations with which they have a collective bargaining or other agreement.

2. This contractor shall include the nondiscrimination and compliance provisions of this clause in all subcontracts to perform work under the contract.

THE UNDERSIGNED CERTIFIES THAT THE CONTRACTOR WILL COMPLY WITH THE ABOVE REQUIREMENTS.

CONTRACTOR OR  
SUBCONTRACTOR NAME: Euro Style Management

CERTIFIED BY:  
NAME: Lilia Bugriyed TITLE: CEO

SIGNATURE: [Signature] DATE: 6/29/20

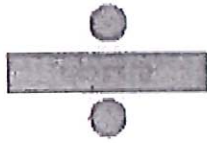

GEORGETOWN DIVIDE  
Public Utility District

P.O. BOX 4240

PHONE (530) 333-4380

GEORGETOWN, CALIFORNIA 95934-4240

FAX (530) 333-2442

gd-pud.org

**ADDENDUM NO. 1**  
Issued June 22, 2020

**SUBJECT:** Georgetown Divide Public Utility District Walton Lake WTP Filter #3 Rehabilitation  
Addendum #1 -- Pre-Bid Meeting Minutes, Questions to Date, and Clarifications

**TO:** All Building Exchanges and Plan Holders:

This addendum shall hereby be made a part of the contract documents to the same extent as though it was originally included. The addendum consists of this cover and all the following pages and attachments.

The Contract Documents are hereby clarified, corrected and changed as indicated below.

Addendum Item	Part/Section	Description of Change
1. Non-mandatory Pre-bid Meeting Minutes and Questions to Date	General	The Pre-Bid meeting minutes and questions to date are provided as Attachment A (2 pages) to this Addendum.
2. Non Mandatory Pre-bid Meeting Sign-in Sheet	General	The Pre-Bid meeting sign-in sheet is provided as Attachment B (1 page) to this Addendum.
3. Existing Filter Information	General	An image of the existing Filter #3 Tag is provided as Attachment C (1 page)
4. Filter #2 Drawings	General	Drawings of Filter #2, which was installed in 2004, are provided as Attachment D (6 pages). The tank size, function, and general layout of the filter interior are similar to Filter #3 (the filter to be rehabilitated), but materials and configuration may vary. <b>The District takes no responsibility for assumptions made by the contractor based on the Filter #2 drawings.</b>
5. Clarification to specifications	Section 2.17, Execution of Contract (1 <sup>st</sup> sentence of 1 <sup>st</sup> paragraph)	<b>Replace the first (1<sup>st</sup>) sentence of the first (1<sup>st</sup>) paragraph of Section 2.17, Execution of Contract with the following text:</b> <i>The successful Bidder will be notified in writing by the District of the award of the Contract within <u>sixty</u> (60) days after opening of Bids, unless the time period is extended as provided in the</i>



GEORGETOWN DIVIDE  
Public Utility District

P.O. BOX 4240  
GEORGETOWN, CALIFORNIA 94031-0240

PHONE (530) 533-1300

FAX (530) 533-2142

gpd.org

6. Clarification to specifications	Section 2.17, Execution of Contract  (1 <sup>st</sup> sentence of 2 <sup>nd</sup> paragraph)	<p><i>Invitation to Bid.</i></p> <p>Replace the first (1<sup>st</sup>) sentence of the second (2<sup>nd</sup>) paragraph of Section 2.17, Execution of Contract with the following text:</p> <p><i>The District will promptly determine whether such Contract, bonds and Insurance are as required by the Contract Documents. Upon such determination, District will forward a fully executed copy of the Contract to the successful bidder and notify the Contractor to schedule the pre-construction meeting. Following the pre-construction meeting, District will issue the Notice to Proceed with the work to the Contractor.</i></p>
------------------------------------	--	--

A copy of this Addendum with the signed acknowledgement below must be attached to your bid proposal or your bid may be considered non-responsive.

If you have any questions or concerns regarding this Addendum please contact Elaine Greif at (530) 537-3854 or [greif@coastlandcivil.com](mailto:greif@coastlandcivil.com).

Thank You,

Approved by:

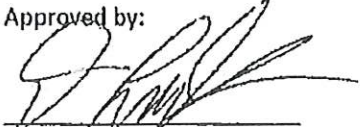
  
Darrell Creeks  
Operations Manager/Superintendent

Prepared by:

  
Elaine Greif  
Assistant Engineer

Contractor's Acknowledgement of Addendum

Addendum No. 1

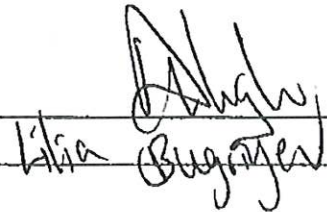
Signed:   
Printed Name: Lilia Bugnizer



GEORGETOWN DIVIDE  
Public Utility District

P.O. BOX 4210

PHONE (530) 333-4355

GEORGETOWN, CALIFORNIA 95931-4210

FAX (530) 333-0142

gd-pud.org

ADDENDUM NO. 2  
Issued June 23, 2020

SUBJECT: Georgetown Divide Public Utility District Walton Lake WTP Filter #3 Rehabilitation  
Addendum #1 – Pre-Bid Meeting Minutes, Questions to Date, and Clarifications

TO: All Building Exchanges and Plan Holders:

This addendum shall hereby be made a part of the contract documents to the same extent as though it was originally included. The addendum consists of this cover and all the following pages and attachments.

The Contract Documents are hereby clarified, corrected and changed as indicated below.

Addendum Item	Part/Section	Description of Change
1. Updated Bid Bond Form	Section 1.5 BID BOND	Please use the revised Bid Bond form (Attachment A; 2 pages)

A copy of this Addendum with the signed acknowledgement below must be attached to your bid proposal or your bid may be considered non-responsive.

If you have any questions or concerns regarding this Addendum please contact Elaine Greif at (530) 537-3854 or [greif@coastlandcivil.com](mailto:greif@coastlandcivil.com).

Thank You,

Approved by:

Darrell Creeks  
Operations Manager/Superintendent

Prepared by:

Elaine Greif  
Assistant Engineer

Contractor's Acknowledgement of Addendum

Addendum No. 2

Signed: \_\_\_\_\_

Printed Name: \_\_\_\_\_

AGENDA ITEM 8.H.

ATTACHMENT 4

ERS BID

1.2 BID

**Walton Water Treatment Plant Filter No. 3 Rehabilitation**

NAME OF BIDDER: ERS Industrial Services, Inc.

STREET ADDRESS: 2120 Warm Springs Ct.

CITY, STATE, ZIP: Fremont, Ca. 94560 *Incorporated in California*

PHONE NO. 510-770-0202 FAX NO. 510-490-3024

CONTRACTOR LICENSE TYPE & NO.:  
General Contractor, Class A & C-33 #724233

The work for which this proposal is submitted is for construction in conformance with the Special Provisions (including the payment of not less than the prevailing wage rates), the project plans, if any, described below, including any addenda thereto, the contract annexed hereto, and also in conformance with the Georgetown Divide Public Utility District specifications.

The Special Provisions for the Work to be done are dated **June 2020**. and are entitled:

**Walton Lake Water Treatment Plant Filter No. 3 Rehabilitation Project**

Bids are to be submitted for the entire work. The amount of the bid for comparison will be the total of all items.

The Bidder shall set forth, for each unit basis item of work, a unit price and a total for the item, and for each lump sum item a total for the item, all in clearly legible figures in the respective spaces provided for that purpose. In the case of unit basis items, the amount set forth under the "Item Total" column shall be the product of the unit price bid and the estimated quantity for the item.

In the case of a discrepancy between the unit price and the total set forth for a unit basis item, the unit price shall prevail, except as provided in (a) or (b), as follows:

- (a) If the amount set forth as a unit price is unreadable or otherwise unclear, or is omitted, or is the same as the amount as the entry in the item total column, then the amount set forth in the item total column for the item shall prevail and shall be divided by the estimated quantity for the item and the price thus obtained shall be the unit price;
- (b) (Decimal Errors) If the product of the entered unit price and the estimated quantity is exactly off by a factor of ten, one hundred, etc. or one-tenth, one-hundredth, etc. from the

entered total, the discrepancy will be resolved by mutual resolution between the two parties.

If both the unit price and the item total are unreadable or otherwise unclear, or are omitted, the bid may be deemed irregular. Likewise, if the item total for a lump sum item is unreadable or otherwise unclear, or is omitted, the bid may be deemed irregular unless the project being bid has only a single item and a clear, readable total bid is provided.

Symbols such as commas and dollar signs will be ignored and have no mathematical significance in establishing any unit price or item total or lump sums. Written unit prices, item totals and lump sums will be interpreted according to the number of digits and, if applicable, decimal placement. Cents symbols also have no significance in establishing any unit price or item total since all figures are assumed to be expressed in dollars and or decimal fractions of a dollar. Bids on lump sum items shall be item totals only; if any unit price for a lump sum item is included in a bid and it differs from the item total, the item total shall prevail.

The foregoing provisions for the resolution of specific irregularities cannot be so comprehensive as to cover every omission, inconsistency, error or other irregularity which may occur in a bid. Any situation not specifically provided for will be determined in the discretion of the Georgetown Divide Public Utility District, and that discretion will be exercised in the manner deemed by the Georgetown Divide Public Utility District to best protect the public interest in the prompt and economical completion of the work. The decision of the Georgetown Divide Public Utility District respecting the amount of a bid, or the existence or treatment of an irregularity in a bid, shall be final.

If this proposal shall be accepted and the undersigned shall fail to enter into the contract and furnish the bond(s) in the sums required by the State Contract Act, with surety satisfactory to the Georgetown Divide Public Utility District, and the insurance certificates within ten (10) days, not including Saturdays, Sundays, and legal holidays, after the Bidder has received notice from the Georgetown Divide Public Utility District that the contract has been awarded, the Georgetown Divide Public Utility District may, at its option, determine that the Bidder has abandoned the contract, and thereupon this proposal and the acceptance thereof shall be null and void and the forfeiture of the security accompanying this proposal shall operate and the same shall be the property of the Georgetown Divide Public Utility District.

When submitting its bid, the Bidder shall include security in the form of cash; cashier's check made payable to the District; a certified check made payable to the District or a bidder's bond executed by an admitted surety insurer, made payable to the District. The amount of security shall be 10 percent of the amount bid. Should the Bidder be awarded the contract, but fail to execute the contract, its security shall be forfeited to the District.

The Bidder has familiarized itself with the nature and extents of the Contract Documents, the Work, the site, the locality where the Work is to be performed, the legal requirements (federal, state and local laws, ordinances, rules, and regulations), and the conditions affecting cost,



progress or performance of the Work, and has made such independent investigations as Bidder deems necessary.

The undersigned, as bidder, declares that the only persons or parties interested in this proposal as principals are those named herein; that this proposal is made without collusion with any other person, firm, or corporation; that he has carefully examined the plans therein referred to; and the contractor proposes, and agrees if this proposal is accepted, that they will contract with the Georgetown Divide Public Utility District, in the form of the copy of the contract annexed hereto, to provide all necessary machinery, tools, apparatus and other means of construction, and to do all the work and furnish all the materials specified in the contract, in the manner and time therein prescribed, and according to the requirements of the District as therein set forth, and that the contractor will take in full payment therefor the following prices, to wit:

### 1.3 BID SCHEDULE

#### Walton Water Treatment Plant Filter #3 Rehabilitation Project

Item No.	Items	Estimated Quantity	Unit of Measure	Price per Unit	Total
1	Mobilization, Insurance, Bonds	1	LS	---	\$ 5000.00
2	Drain, empty, clean, and prepare existing tank	1	LS	---	\$ 22,820
3	Identify and Replace Underdrain Laterals	20	EA	\$ 100.00	\$ 2000.00
4	Supply and Install New Media	1	LS	---	\$ 22,820.00
5	Startup and Testing	1	LS	---	\$ 2000.00
<b>Total Bid Amount:</b>					<b>\$ 54,640.00</b>

---

#### Total Amount in Words

Contractor Company Name: ERS Industrial Services Inc

Fifty Four Thousand, Six Hundred Forty Dollars and Zero Cents.

#### 1.4 Designation of Subcontractors

In compliance with Public Contract Code section 4100 et seq. each bidder shall set forth below the(a) name and location of the mill, shop, or office of each subcontractor who will perform work or labor or render service to the Contractor in or about the construction of the work or improvement to be performed under these specifications in excess of one-half of 1% of the Contractor's total bid, (b) description of the type of work to be performed by each such subcontractor, and (c) portion of the work (expressed in dollar amount) that will be performed by each such subcontractor.

Subletting or subcontracting of any portion of the work in excess of one-half of 1% of the Contractor's total bid as to which no subcontractor was designated in the original bid shall only be permitted in cases of public emergency or necessity, and then only after a finding reduced to writing as a public record of the Agency setting forth the facts constituting the emergency or necessity.

Subcontractor (name and location)	Description of Subcontractor Work	Estimated Portion of Work (in%)
<i>No Subcontractors</i>		



IN WITNESS THEREOF, the above-bounded parties have executed this instrument under their several seals this 25th day of June 2020, the name and corporate seal of each corporate party being hereto affixed and those presents duly signed by its undersigned representative, pursuant to authority of its governing body.

ERS Industrial Services, Inc

(Contractor as Principal)

By:



Lauren Radonich

[Name]

Controller

[Title]

(Seal)

Great American Insurance Company

(Surety)

(Seal)

By:



Catherine A. Pinney

[Name]

Attorney in Fact

[Title]

**CALIFORNIA ALL-PURPOSE ACKNOWLEDGMENT**

**CIVIL CODE § 1189**

A notary public or other officer completing this certificate verifies only the identity of the individual who signed the document to which this certificate is attached, and not the truthfulness, accuracy, or validity of that document.

State of California )

County of Sonoma )

On June 25 2020 before me, Nancy L. Wallis, Notary Public  
Date Here Insert Name and Title of the Officer

personally appeared Catherine A. Pinney  
Name(s) of Signer(s)

who proved to me on the basis of satisfactory evidence to be the person(s) whose name(s) is/are subscribed to the within instrument and acknowledged to me that he/she/they executed the same in his/her/their authorized capacity(ies), and that by his/her/their signature(s) on the instrument the person(s), or the entity upon behalf of which the person(s) acted, executed the instrument.

I certify under PENALTY OF PERJURY under the laws of the State of California that the foregoing paragraph is true and correct.

WITNESS my hand and official seal.



Signature Nancy L. Wallis  
Signature of Notary Public

Place Notary Seal Above

**OPTIONAL**

Though this section is optional, completing this information can deter alteration of the document or fraudulent reattachment of this form to an unintended document.

**Description of Attached Document**

Title or Type of Document: \_\_\_\_\_ Document Date: \_\_\_\_\_

Number of Pages: \_\_\_\_\_ Signer(s) Other Than Named Above: \_\_\_\_\_

**Capacity(ies) Claimed by Signer(s)**

Signer's Name: \_\_\_\_\_

Corporate Officer — Title(s): \_\_\_\_\_

Partner —  Limited  General

Individual  Attorney in Fact

Trustee  Guardian or Conservator

Other: \_\_\_\_\_

Signer Is Representing: \_\_\_\_\_

Signer's Name: \_\_\_\_\_

Corporate Officer — Title(s): \_\_\_\_\_

Partner —  Limited  General

Individual  Attorney in Fact

Trustee  Guardian or Conservator

Other: \_\_\_\_\_

Signer Is Representing: \_\_\_\_\_

# GREAT AMERICAN INSURANCE COMPANY®

Administrative Office: 301 E 4TH STREET • CINCINNATI, OHIO 45202 • 513-369-5000 • FAX 513-723-2740

The number of persons authorized by this power of attorney is not more than SIX

No. 0 21436

## POWER OF ATTORNEY

**KNOW ALL MEN BY THESE PRESENTS:** That the GREAT AMERICAN INSURANCE COMPANY, a corporation organized and existing under and by virtue of the laws of the State of Ohio, does hereby nominate, constitute and appoint the person or persons named below, each individually if more than one is named, its true and lawful attorney-in-fact, for it and in its name, place and stead to execute on behalf of the said Company, as surety, any and all bonds, undertakings and contracts of suretyship, or other written obligations in the nature thereof; provided that the liability of the said Company on any such bond, undertaking or contract of suretyship executed under this authority shall not exceed the limit stated below.

Name	Address	Limit of Power
K. DIXON WRIGHT	ALL OFF	ALL
STACY M. CLINTON	PETALUMA, CALIFORNIA	\$100,000,000
CATHERINE A. PINNEY	TAMMY CARPENTER	

This Power of Attorney revokes all previous powers issued on behalf of the attorney(s)-in-fact named above.

IN WITNESS WHEREOF the GREAT AMERICAN INSURANCE COMPANY has caused these presents to be signed and attested by its appropriate officers and its corporate seal hereunto affixed this 14TH day of MAY, 2020.

Attest

GREAT AMERICAN INSURANCE COMPANY



*Stephen C. Beraha*

Assistant Secretary

*Mark V. Vicario*

Divisional Senior Vice President

MARK VICARIO (877-377-2405)

STATE OF OHIO, COUNTY OF HAMILTON - ss:

On this 14TH day of MAY, 2020, before me personally appeared MARK VICARIO, to me known, being duly sworn, deposes and says that he resides in Cincinnati, Ohio, that he is a Divisional Senior Vice President of the Bond Division of Great American Insurance Company, the Company described in and which executed the above instrument; that he knows the seal of the said Company; that the seal affixed to the said instrument is such corporate seal; that it was so affixed by authority of his office under the By-Laws of said Company, and that he signed his name thereto by like authority.



SUSAN A KOHORST  
Notary Public  
State of Ohio  
My Comm. Expires  
May 18, 2025

*Susan A. Kohorst*

This Power of Attorney is granted by authority of the following resolutions adopted by the Board of Directors of Great American Insurance Company by unanimous written consent dated June 9, 2008.

**RESOLVED:** That the Divisional President, the several Divisional Senior Vice Presidents, Divisional Vice Presidents and Divisional Assistant Vice Presidents, or any one of them, be and hereby is authorized, from time to time, to appoint one or more Attorneys-in-Fact to execute on behalf of the Company, as surety, any and all bonds, undertakings and contracts of suretyship, or other written obligations in the nature thereof; to prescribe their respective duties and the respective limits of their authority; and to revoke any such appointment at any time.

**RESOLVED FURTHER:** That the Company seal and the signature of any of the aforesaid officers and any Secretary or Assistant Secretary of the Company may be affixed by facsimile to any power of attorney or certificate of either given for the execution of any bond, undertaking, contract of suretyship, or other written obligation in the nature thereof, such signature and seal when so used being hereby adopted by the Company as the original signature of such officer and the original seal of the Company, to be valid and binding upon the Company with the same force and effect as though manually affixed.

## CERTIFICATION

I, STEPHEN C. BERAHA, Assistant Secretary of Great American Insurance Company, do hereby certify that the foregoing Power of Attorney and the Resolutions of the Board of Directors of June 9, 2008 have not been revoked and are now in full force and effect.

Signed and sealed this 25th day of June, 2020



*Stephen C. Beraha*

Assistant Secretary

**CALIFORNIA ALL-PURPOSE ACKNOWLEDGMENT**

**CIVIL CODE § 1189**

A notary public or other officer completing this certificate verifies only the identity of the individual who signed the document to which this certificate is attached, and not the truthfulness, accuracy, or validity of that document.

State of California )  
County of Alameda )  
On June 26, 2020 before me, Karen Janis Byers, Notary Public,  
Date Here Insert Name and Title of the Officer  
personally appeared Lauren Radonich  
Name(s) of Signer(s)

who proved to me on the basis of satisfactory evidence to be the person(s) whose name(s) is/are subscribed to the within instrument and acknowledged to me that ~~he/she/they~~ executed the same in his/her/their authorized capacity(ies), and that by his/her/their signature(s) on the instrument the person(s), or the entity upon behalf of which the person(s) acted, executed the instrument.

I certify under PENALTY OF PERJURY under the laws of the State of California that the foregoing paragraph is true and correct.

WITNESS my hand and official seal.

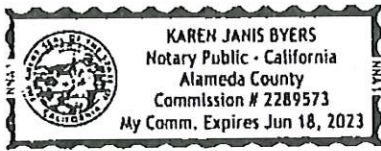

Signature Karen Janis Byers  
Signature of Notary Public

Place Notary Seal Above

**OPTIONAL**

Though this section is optional, completing this information can deter alteration of the document or fraudulent reattachment of this form to an unintended document.

**Description of Attached Document**

Title or Type of Document: Bid Bond Georgetown Divide PUD  
Document Date: \_\_\_\_\_ Number of Pages: \_\_\_\_\_  
Signer(s) Other Than Named Above: \_\_\_\_\_

**Capacity(ies) Claimed by Signer(s)**

Signer's Name: \_\_\_\_\_  
 Corporate Officer — Title(s): \_\_\_\_\_  
 Partner —  Limited  General  
 Individual  Attorney in Fact  
 Trustee  Guardian or Conservator  
 Other: \_\_\_\_\_  
Signer Is Representing: \_\_\_\_\_

Signer's Name: \_\_\_\_\_  
 Corporate Officer — Title(s): \_\_\_\_\_  
 Partner —  Limited  General  
 Individual  Attorney in Fact  
 Trustee  Guardian or Conservator  
 Other: \_\_\_\_\_  
Signer Is Representing: \_\_\_\_\_

**1.6 Experience Qualifications**

The Bidder has been engaged in the contracting business, under the present business name for 24 years. Experience in work of a nature similar to that covered in the Bid extends over a period of 24 years.

The Bidder, as a contractor, has never failed to satisfactorily complete a contract awarded to it, except as follows:

None

---



---



---

The following contracts have been satisfactorily completed in the last three years for the persons, firm or entity indicated: (Bidder may provide additional experience statements).

<u>Year</u>	<u>Owner</u>	<u>Type of Work</u>	<u>Contract Amount</u>
<u>2020</u>	<u>Monterey Bay Aquarium</u>	<u>Filter Change Out</u>	<u>142,070.00</u>
<u>2019</u>	<u>City of Redding</u>	<u>(2) Filter New Media &amp; Underdrains</u>	<u>288,650.00</u>
<u>2020</u>	<u>Calaveras County</u>	<u>Media change out and Coatings (2) Filters</u>	<u>406,940.00</u>
<u>2019</u>	<u>Millview water District</u>	<u>Rehab with Coatings (4) Pressure vessels</u>	<u>700,060.00</u>



The following is a list of plant and equipment owned by the Bidder, which is definitely available for use on the proposed work as required. (Bidder may provide additional list of plant and equipment available).

<u>Quantity</u>	<u>Name, Type and Capacity</u>	<u>Condition</u>	<u>Location</u>
-----------------	--------------------------------	------------------	-----------------

	<u>See attached- all are in good condition</u>		
--	--	--	--

--	--	--	--

--	--	--	--

--	--	--	--

--	--	--	--

--	--	--	--

--	--	--	--

--	--	--	--

**VEHICLE LIST**

ERS #	YEAR	MAKE	MODEL	BODY TYPE	LICENSE PLATE	LOCALE	ENGINE	VEHICLE WEIGHT
24	2001	Trail-Eze	Flatbed (Forklift) #24	Trailer	4CP7560	CA	N/A	2,575
26	2000	Prowler	35'	Trailer	1JC4653	ID	N/A	4,780
29	2015	Trailmobile	1400VN Flatbed (Gooseneck) #29	Trailer	4NY1847	CA	N/A	2,900
30	2016	Orlandi	Cargo Trailer (Paint - Enduraflex) #30	Trailer	4NY3776	CA	N/A	2,900
34	2016	Orlandi	Cargo Trailer (Paint - Sherplate) #34	Trailer	4PG5953	CA	N/A	26,000
70	1992	International	4700 (5 Yard) #70	Dump Truck	4Z54197	CA	5.9 L L6 Diesel	50,000
80	2012	F750	Dump Truck 5 Yards	Dump Truck	84793P1	CA	8.5L L4 Diesel	20,000
82	1994	Freightliner	FL106 (8 Yard) #82	Dump Truck	98884E2	CA	7.3L V8 DI	5,396
87	2001	Ford	F450 Super Duty Lariat #87	Flatbed Truck	6U82356	CA/ Spare	5.4L V8 EFI	5,396
88	2004	Ford	F150 FX4 Lariat #88	Pickup	B32393X	WA	5.4L V8 EFI	60,000
90	2004	Ford	F150 FX4 Lariat #80	Pickup	7H49522	CA/ Shop	12.7L L6 Diesel	26,000
91	1999	Freightliner	FLD120 (Crane) #91	Truck/ Tractor	7N38065	CA	6.0L V8 Diesel	26,000
92	2005	Ford	F550 Super Duty #92	Truck	7R09270	CA/ Shop	6.0L V8 FI	26,000
95	2005	Ford	F450 Super Duty Lariat #95	Truck	8A30512	CA/ Andrew	6.0L V8 FI	26,000
97	2007	Ford	F450 Super Duty Lariat #97	Truck	8J04920	CA/ Spare	4.5L V8 EFI	5,296
98	2008	Ford	F150 FX4 HD/KR/Lariat Limited #98	Pickup	8R08225	CA/ Gary	5.4L V8 EFI	5,296
101	2008	Ford	F150 FX4 HD/KR/Lariat Limited #101	Pickup	C96984C	WA	6.7L V8 DI	7,413
102	2011	Ford	F350 Super Duty KR/Lariat #102	Pickup	41531B1	CA/ Gabriel	3.5L V6 DI	5,395
103	2014	Ford	F150 FX4/KR/Lariat/Limited/Platinum #103	Pickup	31668P1	CA/ Rick	3.5L V6 DI	5,395
104	2014	Ford	F150 FX4/KR/Lariat/Limited/Platinum #104	Pickup	31968P1	CA/ Ricky	3.5L V6 DI	4,864
105	2015	Ford	F150 KR/Lariat/Platinum #105	Pickup	79705U1	CA/ Bradford	3.5L V6 DI	4,864
106	2015	Ford	F150 KR/Lariat/Platinum #106	Pickup	79704U1	CA/ Randy	6.7L V8 DI	26,000
107	2015	Ford	F450 Super Duty Lariat #107	Truck	71081W1	CA/ Alberto	3.5L V6 DI	4,784
108	2016	Ford	F150 KR/Lariat/Limited/Platinum #108	Pickup	79161A2	CA/ Lauren	14.8L L6 Diesel	80,000
109	2011	Freightliner	Cascadia 125 #109	Tractor	9E12423	CA	3.5L V6 DI	12,000
110	2018	F350	F350 Crew/Super Crew/Crew Max	Truck	56742J2	CA/ Nik	6.7L V8 DI	7,242
111	2018	F150	F150 Crew/Super Crew/Crew Max	Pickup	58783L1	CA/ Brad	6.7L Diesel	16,500
112	2016	F450	F450 Crew Cab 4 Door	Pickup	1VA9145	CA/	N/A	13,100
534	1995	Clement	End Dump #534	Trailer	4AV6249	CA	N/A	12,960
535	1997	Fruehauf	Flat Deck #535	Trailer		CA	N/A	

**EQUIPMENT LIST**

ADD	ERS #	YEAR	MAKE	MODEL	BODY TYPE	LICENSE PLATE	LOCALE	WEIGHT
2		1998	WaterMaze	CL30A	Water Recycle System	No DMV	Yard	N/A
	3	1995	Thompson	SPM252	6' Pump/Trailer	No DMV	Yard	N/A
	4	1999	Landa	5-3500	Pressure Washer	No DMV	Yard	N/A
	5	2002	Landa	5-3500	Pressure Washer	No DMV	Yard	N/A
	6	2005	Northstar	2700PSI	Pressure Washer	No DMV	Yard	N/A
	7	2019	Karcher	GX390	Cold Water Pressure Washer	No DMV	Yard	N/A
	8	1999	SkyTrak	10054	Teleshander	No DMV	Yard	20,000
	9	2019	Karcher	GX390	Cold Water Pressure Washer	No DMV	Yard	N/A
	10	1970	Case	W-18	Wheel Loader	No DMV	Yard	N/A
	11	2006	Bobcat	T190	Skid-Steer Loader	No DMV	RBV	8,000
	14	1992	Hurricane	17R622	Vacuum/Trailer	(S)E421440	Yard	N/A
	15	1999	Hurricane	755	Vacuum/Trailer	4Z2160	Yard	14,000 300
	17	1993	Hurricane	17R622	Vacuum/Trailer	(S)E427204	Yard	2,445
	19	1988	Hurricane	522	Vacuum/Trailer	(S)E459260	Yard	N/A
	20	1994	Hyster	H60XL	Forklift	No DMV	Yard	9,000
	21	2009	Genie Lifts	GR-IS	Electrical Vertical Lifts	No DMV	Yard	
	22	2009	Genie Lifts	GR-IS	Electrical Vertical Lifts	No DMV	Yard	
	23	1996	Hyster	H60XM	Forklift	No DMV	Yard	9,000
	24	2001	Trail Eze	H60XM	Forklift Trailer	4CP7560	Yard	2575
	25	2011	Toyota	8FGUJ30	Forklift	No DMV	Yard	6000
	26	2000	Prowler	35' ?	Trailer	1JC4653	ID	N/A
	27	1999	Hyster	H50XL	Forklift	No DMV	Yard	9,000
	28	1999	Hyster	H50XM	Forklift	No DMV	Yard	9,000
30a		2014	Graco	XP50	Component Sprayer	No DMV	#30	N/A
	31	2002	Concepts Designs	CDH-R-126	Skid Mounted DH	No DMV	Yard	N/A
	32	2008	Kubota	RTV900	Utility Cart	No DMV	RBV	N/A
	33	2006	New Holland	TC40	Wheel Loader	No DMV	RBV	N/A
	34	2016	Continental Cargo	TE714TA2	7x14 Cargo Trailer	4PG6953	Yard	2,900
34a		2014	Graco	XP50	Component Sprayer	No DMV	#34	N/A
	35	1997	NBL	362000-660	Hydro Pressure Cleaner	(S)E628229	Yard	N/A
	35a	2019	Bringham	BMFG-902 Gun BMFG-901 Box	Hand Tool High Pressure	No DMV	Yard	n/a
	36	2010	Sullair	375HJD3	Air Compressor	(S)E900151	Yard	N/A
	37	2010	Sullair	375HJD3	Air Compressor	(S)E628276	Yard	N/A
	38	2018	Clemco	20601	Spin-Blast for 8"-36" ID Pipe	No DMV	Yard	N/A



GEORGETOWN DIVIDE  
**Public Utility District**

P.O. BOX 4210

PHONE (530) 333-4366

GEORGETOWN, CALIFORNIA 95931-6210

FAX (530) 333-2142

gd.pud.org

- **Q: Are there circumstances where more than 14-days will be allowed for the filter to be taken offline?**  
**A: The District can only commit to 14-days at this time as it depends on water demand at the time. If demand is down, there may be flexibility, but the successful contractor shall be prepared to complete the work and anticipated extra work in the 14-day window.**
- **Q: Are there any record drawings of the filter?**  
**A: There are no reliable drawings of Filter #3 (the filter to be rehabilitated). There are drawings of Filter #2, which was installed in 2004. The size and general layout of the filter interior is similar, but materials vary. The Filter #2 drawings are provided as an attachment to Addendum #1 (see addendum #1, Item 4), but the District takes no responsibility for assumptions made by the contractor based on the Filter #2 drawings.**
- **Q: Is there a concrete floor in the filter?**  
**A: Yes, there is a concrete floor that the underdrain header is partially imbedded in.**
- **Q: Do you have any recommendations for media supplier?**  
**A: No. The supplier/manufacturers listed in the contract documents would likely have that information, but no specific supplier is required as long as the media conforms to the requirements of AWWA B100 "Granular Filter Material", is compliant with NSF/ANSI 61, and is specifically for water treatment applications. Per specification section 6-1.13 A3, the supplier shall provide written certification that the materials supplied are in full compliance with the specifications.**

ATTACHMENT B

GEORGETOWN DIVIDE

Public Utility District

PO BOX 4240  
 GEORGETOWN, CALIFORNIA 90324-4240  
 PHONE (530) 333-4326  
 FAX (530) 333-4442  
 gd-pud.org

PRE-BID MEETING SIGN-IN SHEET

Project: Walton Lake Water Treatment Plant Filter #3 Rehabilitation

Date: June 18, 2020 9:30 am

Location: Walton WTP, off of Wentworth Springs Rd at Balderston Rd

Company Name	Representative Name	Email	Phone
<i>EVRO STYLE MANAGEMENT</i>	<i>2ac Loussou Mio</i>	<i>SUTPOES@ESM.CC</i>	<i>916 331 4858</i>
<i>BWB GENERAL ENGINEERING CONTRACTORS</i>	<i>BEN NREHNOH</i>	<i>BEN@BWB.CONSTRUCTION</i>	<i>(916) 765-2867</i>
<i>PROBUILDERS</i>	<i>ROBERT LEWIS</i>	<i>SEBASTIANO@PROBUILDERS</i>	<i>916 225 0373</i>
COASTLAND (Engineer/PM)	ASA UTTERBACK	autterback@coastlandcivil.com	530-537-3826
COASTLAND (Engineer/PM)	ELAINE GREIF	greif@coastlandcivil.com	530-537-3854
GDPUD	DARRELL CREEKS	dacreeka@gd-pud.org	530-333-4356



PROLOGICS



W

R

MAT. BD.

SANTA FE TRAIL

GREAT CO., INC.

SANTA FE SPRINGS, SANTA FE

MAX. W.P. 75 P.S. 450

WATER X AIR S.I.M.

MFR. NO. 19611

SN. 1/4 NO. 5/8

TERS

TERS

TERS

1980

# ATTACHMENT D

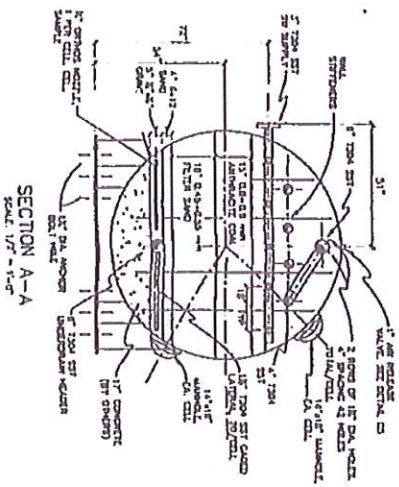
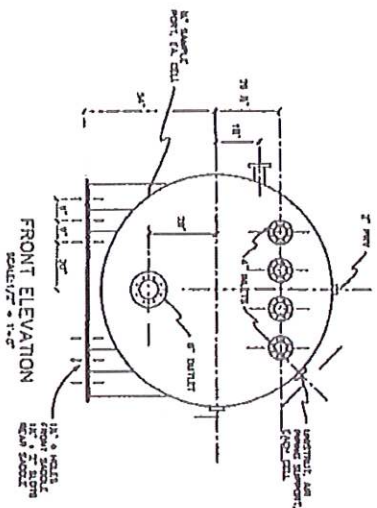
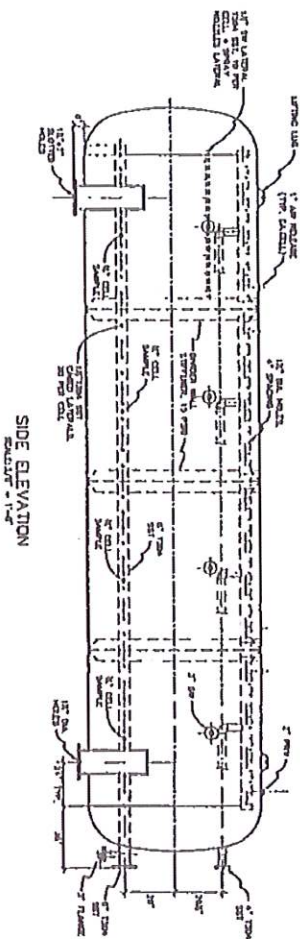
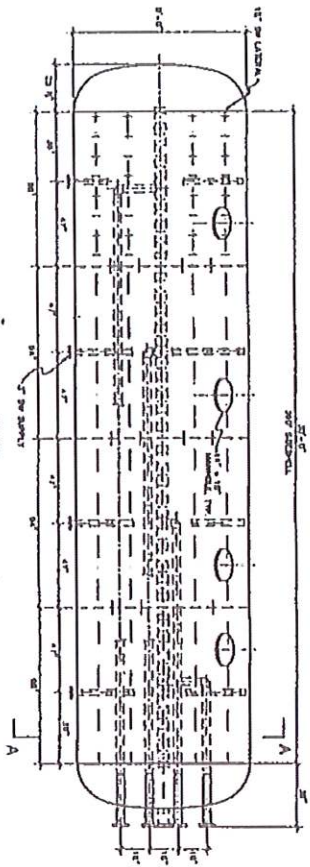

- NOTE:**
1. PROCESSING VESSEL WILL BE 90 PPM ASBESTOS REMOVAL.
  2. VESSEL FILTERS WILL RECEIVE A NEAR WHITE SANDBLAST (PER 10) AND 3 COATS OF PROTECTIVE EPOXY WITH ANTI-ACID COAT (S-12 WALK COAT). FILTERS WILL BE WHITE.
  3. VESSEL ESTIMATORS WILL RECEIVE A COMPLETION SAND-BLAST (PER 10) AND 3 COATS OF ZINC PRIMER, PROTECTIVE EPOXY OR EPOXY AND GELCO FOR FIBER COAT.
  4. FILTER DESIGN PARAMETERS:
    - a. HYDRAULIC LOADING RATE = 720 GPM
    - b. MAXIMUM RECOMMENDED BACKWASH RATE = 720 GPM
    - c. BACKWASH DURATION = 6-10 MINUTES
    - d. PRESSURE FILTER TO SANDING RATE = 720 GPM
    - e. FILTER MEDIA AREA = 541.3 SQUARE FEET
    - f. FILTER MEDIA DEPTH = 24 INCHES
    - g. SURFACE WASH FILTER RATE = 125 GPM
    - h. SURFACE WASH DURATION PER SANDER ZONE 1. (DRAINAGE REGION PERIOD) 180 SECS
  5. REFER TO SPEC'S FOR SURFACE WASH NOZZLE MODEL AND MANUFACTURER.

These drawings are for Filter #2 at the Malton Lake WTP, which is similar in function and layout as Filter #3 (the filter to be rehabilitated). These drawings are provided for reference only and the District takes no responsibility for the information inferred by the Contractor about Filter #3 based on these drawings.

NO.	DATE	BY	CHKD.

FILTER #2 REPLACEMENT MALTON LAKE WTP		RESCUE ENGINEERS INCORPORATED	
DRAWING NO. L-1717	SHEET NO. 1355	DATE 10/28	SCALE 1/2" = 1'-0"

These drawings are for Filter #2 at the Walton Lake WTP, which is similar in function and layout as Filter #3 (the filter to be rehabilitated). These drawings are provided for reference only and the District takes no responsibility for the information inferred by the Contractor about Filter #3 based on these drawings.

Q.C. No.	1
REV. DATE	1/13/04
REV. NO.	1
DWG. NO.	DF 9

WORK ORDER NO.  
10066  
SHEET 1 OF 5

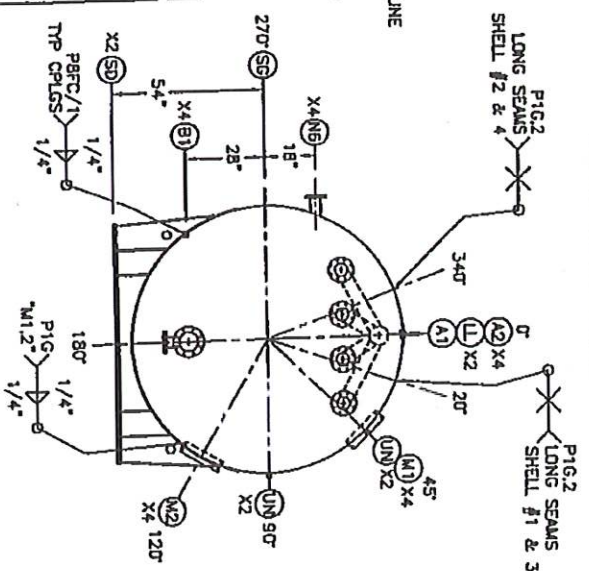
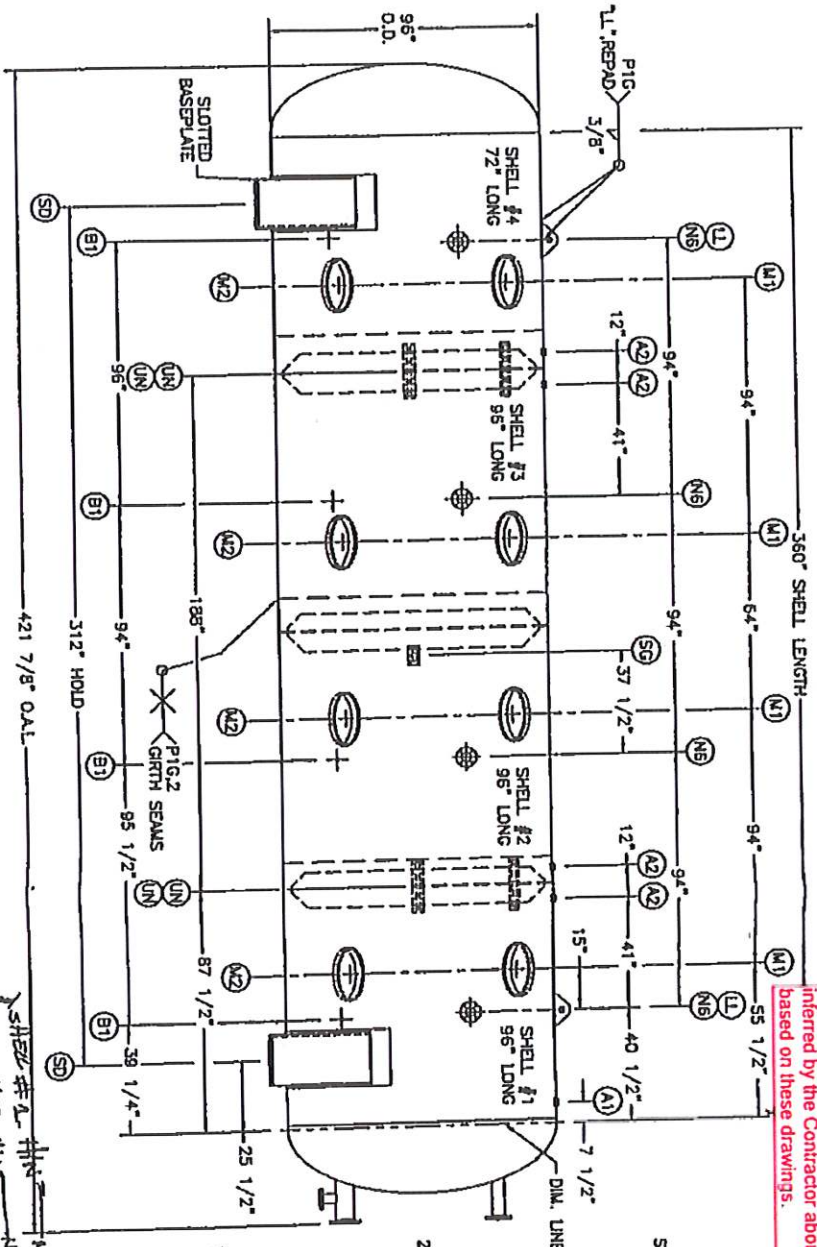

- NOTES:
- FOUNDATION DESIGN BY OTHERS.
  - DANGER PLATES DESIGNED FOR 15 PSD.
  - FLANGE BOLT HOLES TO STRADDLE CENTERLINES.
  - DEBURR ALL SHARP EDGES.

DETAIL "UN"

SHELL #1 - 96" LONG  
SHELL #2 - 95" LONG  
SHELL #3 - 95" LONG  
SHELL #4 - 72" LONG

NT3935-A2  
NT3935-A2  
NT3935-A2  
NT3935-A2

PIG. 3/8"

13477 YORBA AVENUE CHINO, CALIFORNIA 91710	13477 YORBA AVENUE CHINO, CALIFORNIA 91710	DELETE SST	CUSTOMER NAME	RESOLVE ENGINEERING INC	PROJECT NAME	PIG.2 FILTER / WALTON LAKE WTP	MODEL NO:	LF78-300E	DATE	1/13/04	
PH: (909) 828-2778 FAX: (909) 828-5779	PH: (909) 828-2778 FAX: (909) 828-5779	EXTERNAL PAINT	PROJECT NO.	20993	NATIONAL BOARD NO. 2	WILL ADVISE	APPROD BY:				
		BASEPLATE HOLES	DESIGN DATE	11/13	DESIGN/DATE	11/13	TEST PRESSURE	65	PSI	VOLUME	12270 GAL
		SHOP RELEASE	TEST PRESSURE	65	PSI	VOLUME	12270	GAL	WEIGHT	19000	LB
		TEST PRESSURE	65	PSI	VOLUME	12270	GAL	WEIGHT	19000	LB	
		TEST PRESSURE	65	PSI	VOLUME	12270	GAL	WEIGHT	19000	LB	

CONSTRUCTION AND STAMPING PER  
A.S.A.E. SECTION VIII, DIVISION 1

SHIELD / 1/4" 3500 7/8" SA-516.70  
GASKET / 6870 SEAL-RITE 3/8" THK SA-516.70  
INTERIOR LINING: SP-10, 9-12 MILS THICK 140 EPDM  
EXTERIOR COATING: SP-E, 3 MILS THICK 88-1271  
RADIOGRAPHY: NONE  
CORROSION ALLOWANCE: NONE



These drawings are for Filter #2 at the Walton Lake WTP, which is similar in function and layout as Filter #3 (the filter to be rehabilitated). These drawings are provided for reference only and the District takes no responsibility for the information inferred by the Contractor about Filter #3 based on these drawings.

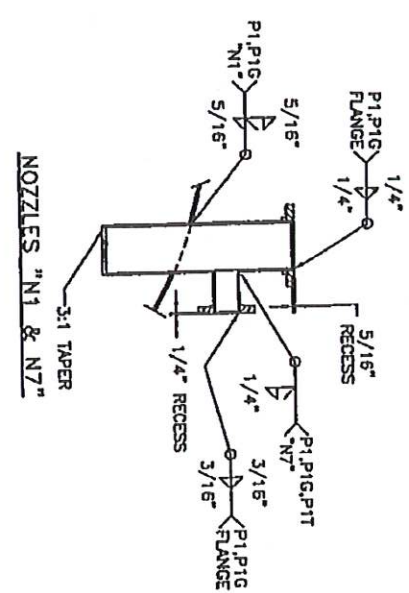
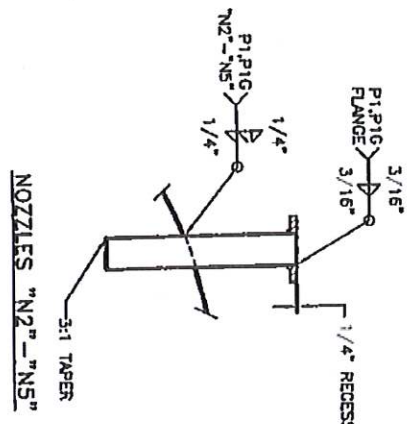
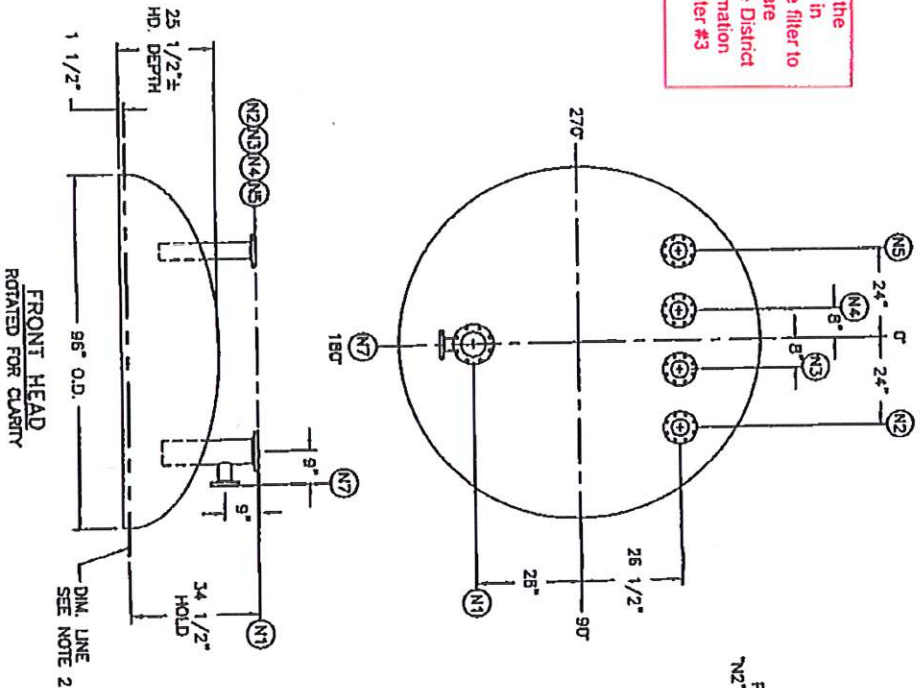

3. FLANGE BOLT HOLES TO STRADDLE CENTERLINES.
2. PUNCH MARK INSIDE/OUT @ 0°, 90°, 180°, 270°.
1. DEBURR SHARP EDGES.

NOTES:

**SOUTHEAST ENGINEERING**  
 13477 YORBA AVENUE  
 CHINO, CALIFORNIA 91710  
 PH. (909) 828-2778  
 FAX. (909) 828-5779

REV	DATE	DESCRIPTION	APP'VD
4	1/13	DELETE 'SS'	
3	12/8	EXTERNAL PAINT	
2	12/4	BASEPLATE HOLES	
1	11/5	SHOP RELEASE	
0	10/22	SUBMITTAL	

CONSTRUCTION AND STAMPING PER  
 A.S.M.E. SECTION VIII, DIVISION 1

WORK ORDER NO.  
 10066  
 SHEET 2 OF 5

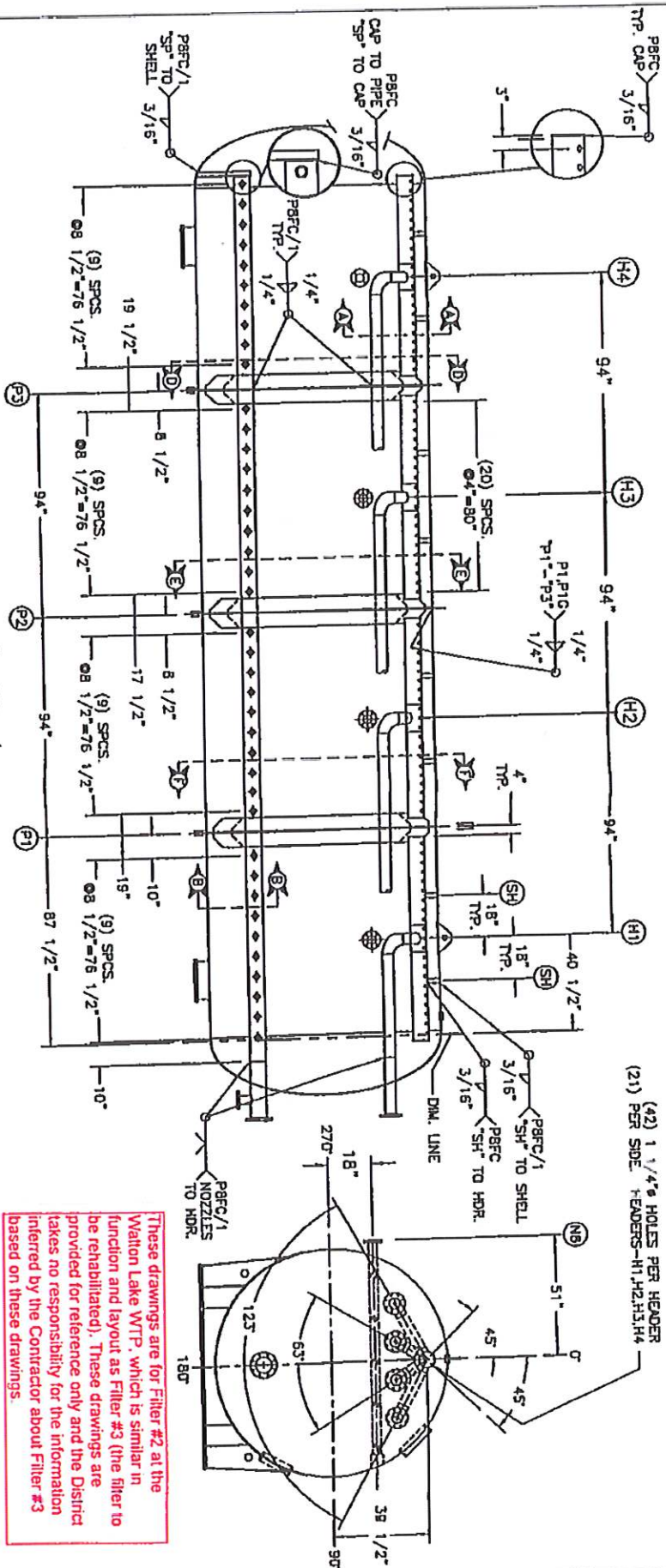

(42) 1 1/4" HOLES PER HEADER  
(21) PER SIDE HEADERS-H1,H2,H3,H4

These drawings are for Filter #2 at the Walton Lake WTP, which is similar in function and layout as Filter #3 (the filter to be rehabilitated). These drawings are provided for reference only and the District takes no responsibility for the information inferred by the Contractor about Filter #3 based on these drawings.

NOTES: 1. DEBURR ALL SHARP EDGES.

**SOUTHEAST GATE ENGINEERING**  
13477 YORBA AVENUE  
CHINO, CALIFORNIA 91710  
PH: (909) 328-2778  
FAX: (909) 328-5778

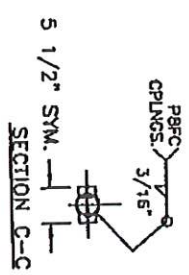
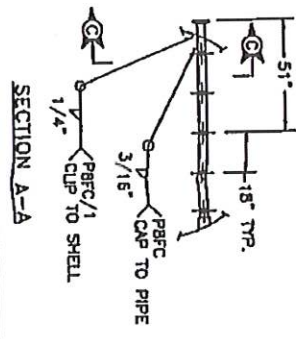
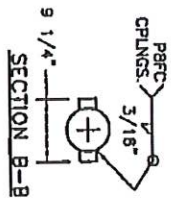

REV	DATE	DESCRIPTION	APPV'D
4	1/13	DELETE 'SS'	
3	12/9	EXTERNAL PAINT	
2	12/4	BASEPLATE HOLES	
1	11/5	SHOP RELEASE	
0	10/22	SUBMITAL	

CONSTRUCTION AND STAMPING PER  
A.S.M.E. SECTION VIII, DIVISION 1

WORK ORDER NO.  
10066  
SHEET 4 OF 5

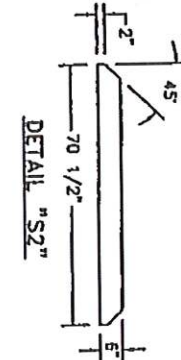
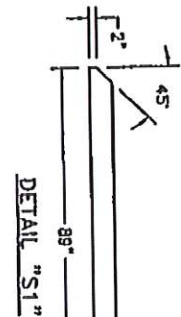
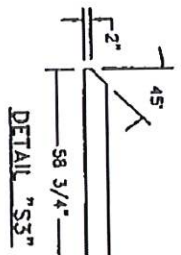
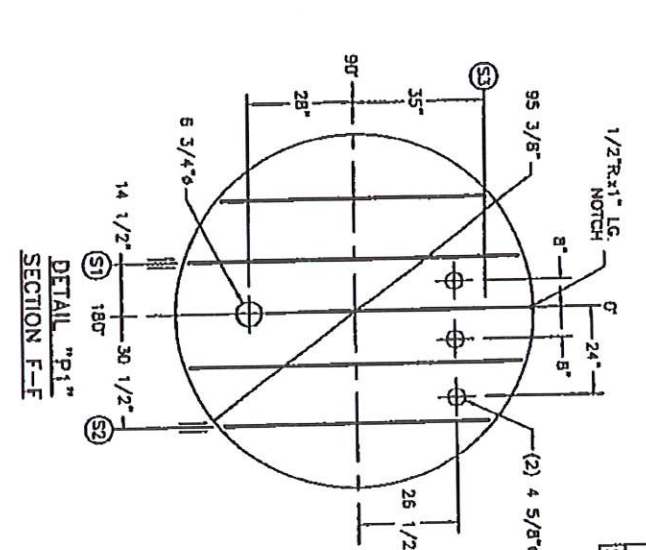
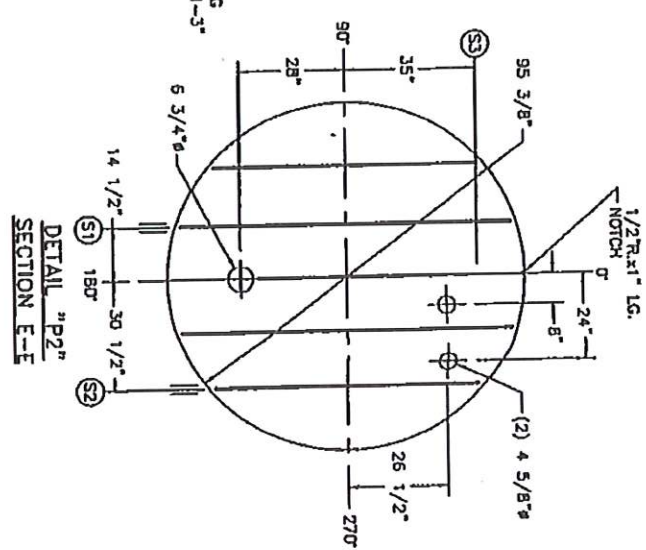
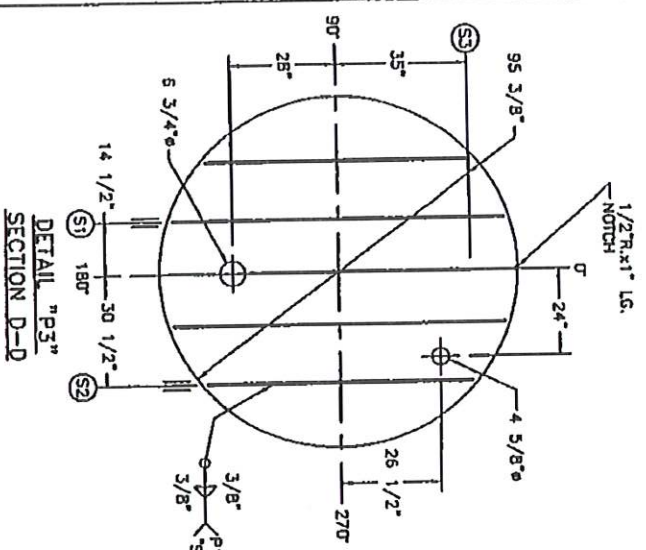

These drawings are for Filter #2 at the Walton Lake WTP, which is similar in function and layout as Filter #3 (the filter to be rehabilitated). These drawings are provided for reference only and the District takes no responsibility for the information inferred by the Contractor about Filter #3 based on these drawings.

NOTES:  
1. DEBURR SHARP EDGES.

13477 YORBA AVENUE  
CHINO, CALIFORNIA  
91710  
PH.(909)528-2779  
FAX.(909)528-6778

REV	DATE	DESCRIPTION	APP'V'D
4	1/13	DELETE "SS"	
3	12/9	EXTERNAL PAINT	
2	12/4	BASEPLATE HOLES	
1	11/5	SHOP RELEASE	
0	10/22	SUBMITTAL	

CONSTRUCTION AND STAMPING PER  
A.S.M.E. SECTION VIII, DIVISION 1

WORK ORDER # ML  
10056  
SHEET 5 OF 5

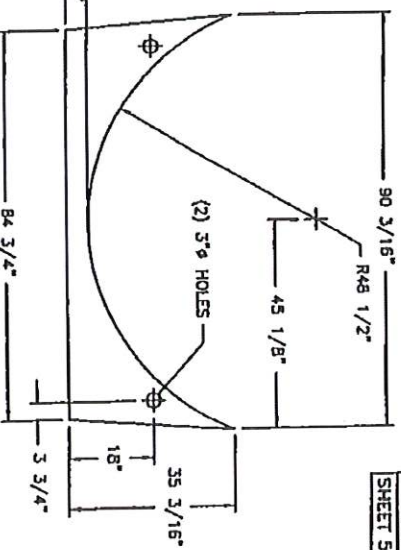
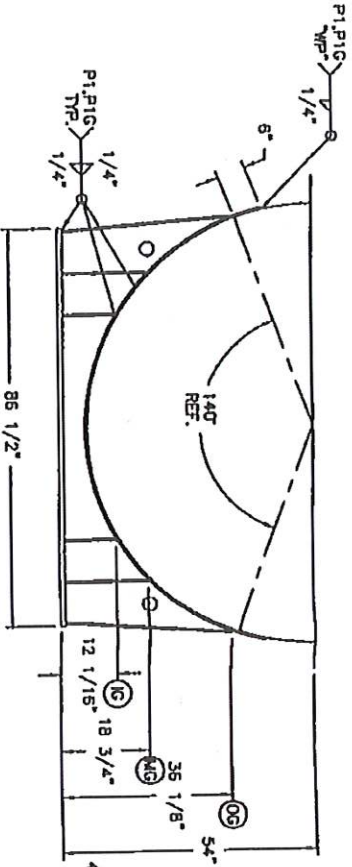
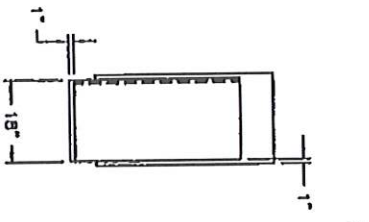

DETAIL "WB"

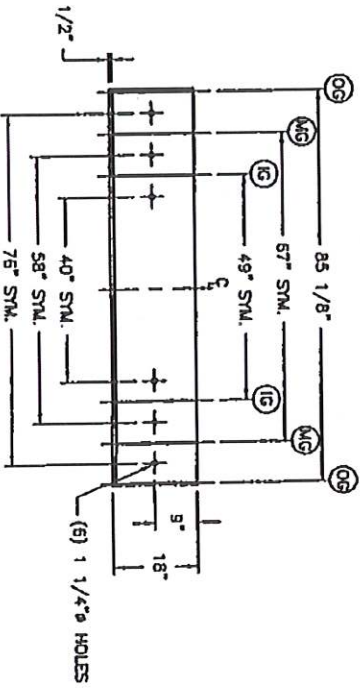

FRONT BASEPLATE



REAR BASEPLATE

DIMS. NOT SHOWN  
SAME AS ABOVE

(6) 1 1/4" x 2" LG. SLOTS

NOTES:  
1. DEBURR SHARP EDGES.

**SOUTE GATE ENGINEERING**  
13477 YORBA AVENUE  
CHINO, CALIFORNIA 91710  
PH. (909) 625-2779  
FAX. (909) 628-6779

These drawings are for Filter #2 at the Walton Lake WTP, which is similar in function and layout as Filter #3 (the filter to be rehabilitated). These drawings are provided for reference only and the District takes no responsibility for the information inferred by the Contractor about Filter #3 based on these drawings.

REV	DATE	DESCRIPTION	APP'D
4	1/13	DELETE "SS"	
3	12/9	EXTERNAL PAINT	
2	12/4	BASEPLATE HOLES	
1	11/5	SHOP RELEASE	
0	10/22	SUBMITTAL	

CONSTRUCTION AND STAMPING PER  
A.S.M.E. SECTION VIII, DIVISION 1



# GEORGETOWN DIVIDE Public Utility District

P.O. BOX 4210

PHONE (530) 533-4300

GEORGETOWN, CALIFORNIA 95931-0210

FAX (530) 533-5192

gd.pud.org

## ADDENDUM NO. 2 Issued June 23, 2020

**SUBJECT: Georgetown Divide Public Utility District Walton Lake WTP Filter #3 Rehabilitation  
Addendum #1 – Pre-Bid Meeting Minutes, Questions to Date, and Clarifications**

**TO: All Building Exchanges and Plan Holders:**

This addendum shall hereby be made a part of the contract documents to the same extent as though it was originally included. The addendum consists of this cover and all the following pages and attachments.

The Contract Documents are hereby clarified, corrected and changed as indicated below.

Addendum Item	Part/Section	Description of Change
1. Updated Bid Bond Form	Section 1.5 BID BOND	Please use the revised Bid Bond form (Attachment A; 2 pages)

A copy of this Addendum with the signed acknowledgement below must be attached to your bid proposal or your bid may be considered non-responsive.

If you have any questions or concerns regarding this Addendum please contact Elaine Greif at (530) 537-3854 or [greif@coastlandcivil.com](mailto:greif@coastlandcivil.com).

Thank You,

Approved by:

Barrell Creeks  
Operations Manager/Superintendent

Prepared by:

Elaine Greif  
Assistant Engineer

### Contractor's Acknowledgement of Addendum

Addendum No. 2

Signed:

Printed Name:

Lauren Radonich

1.5 Bid Bond

KNOW ALL MEN BY THESE PRESENTS, THAT WE, THE UNDERSIGNED

\_\_\_\_\_, Contractor as Principal; and \_\_\_\_\_, as Surety, are hereby held and bound unto Georgetown Divide Public Utility District, hereinafter called the District, in the sum of \$\_\_\_\_\_ which sum is equal to at least ten percent of the total amount of the Bid, payment of which sum, well and to be made, we hereby jointly and severally bind ourselves, our heirs, executors, administrators, successors, and assigns.

The condition of the above obligation is such that whereas the Principal has submitted to the District a certain Bid, attached hereto and hereby made a part hereof, to enter into a Contract in writing, for the construction of the following public works project:

**Walton Lake Water Treatment Plant Filter #3 Rehabilitation Project**

NOW, THEREFORE,

(a) If the Bid is rejected, or in the alternate,

(b) If the Bid is accepted and the Principal shall sign and deliver a Contract, in the form of the Contract attached hereto and shall execute and deliver Performance and Payment Bonds in the forms attached hereto and shall deliver proof of insurance (all completed in accordance with the Contract Documents), and shall in all other respects perform the agreement created by the acceptance of the Bid;

Then, this obligation shall be void, otherwise the same shall remain in force and effect; it being expressly understood and agreed that the liability of the Surety for any and all default of the Principal hereunder shall be the amount of this obligation as herein stated.

The Surety, for value received, hereby stipulates and agrees that the obligations of said Surety and its bond shall be in no way impaired or affected by any extension of the time within which the District may accept such Bid, and said Surety does hereby waive notice of any such extension.

IN WITNESS THEREOF, the above-bounded parties have executed this instrument under their several seals this \_\_\_\_\_ day of \_\_\_\_\_ 2020, the name and corporate seal of each corporate party being hereto affixed and those presents duly signed by its undersigned representative, pursuant to authority of its governing body.

\_\_\_\_\_  
(Contractor as Principal)

By: \_\_\_\_\_

(Seal)

\_\_\_\_\_  
[Name]

\_\_\_\_\_  
[Title]

(Surety)

\_\_\_\_\_

(Seal)

By: \_\_\_\_\_

\_\_\_\_\_  
[Name]

\_\_\_\_\_  
[Title]

AGENDA ITEM 8.H.

ATTACHMENT 5

EMAIL



## Elaine Greif

---

**From:** ESM <support@esm.cc>  
**Sent:** Monday, July 6, 2020 8:48 AM  
**To:** Asa Utterback  
**Cc:** Elaine Greif  
**Subject:** RE: Georgetown Divide PUD: Walton lake WTP Filter # 3 Rehab project  
**Attachments:** envirotrol Walton Lake Filter #3 rehab, material quote.pdf

Asa,  
Please see attached quote from Envirotrol.  
ESM

---

**From:** Asa Utterback [mailto:autterback@coastlandcivil.com]  
**Sent:** Thursday, July 2, 2020 4:09 PM  
**To:** ESM <support@esm.cc>  
**Cc:** Elaine Greif <greif@coastlandcivil.com>  
**Subject:** RE: Georgetown Divide PUD: Walton lake WTP Filter # 3 Rehab project

Ms. Bugriyev,

Thanks for the information. We'll look into the information and contact references next week and get back to you.

Regarding the work which you mentioned would be performed by Envirotrol, please clarify how much of the work you are planning to have Envirotrol perform on the work in this project bid.

Thank you.

**Asa Utterback, PE** | *Senior Engineer*

**COASTLAND**

11641 Blocker Drive, Suite 170 | Auburn, CA 95603  
530.537.3826 Tel | 530.304.9987 Mobile

**COVID-19 UPDATE: The Coastland team is working remotely in accordance with the shelter-in-place directives. We will remain accessible via email and cell phone.**

---

**From:** ESM <[support@esm.cc](mailto:support@esm.cc)>  
**Sent:** Thursday, July 2, 2020 2:14 PM  
**To:** Asa Utterback <[autterback@coastlandcivil.com](mailto:autterback@coastlandcivil.com)>  
**Subject:** FW: Georgetown Divide PUD: Walton lake WTP Filter # 3 Rehab project

Mr. Utterback,

For your consideration regarding ESM's qualifications and ability to perform on the referenced project we offer the following information.

Euro style Management , is a Class A, B and C-33 licensed contractor and has performed a variety of projects with CalTrans and all major Water and Wastewater agencies in California. Our performance ranges from bridge work,

earthwork, tank, digesters, clarifiers and headwork. We employ expert welders, concrete masons and paint journeymen.

Current completed work:

Scotts Valley Water District, Sequoia Tank Interior Repairs  
Remove and install new center column Ring and support, apply new lining.  
David McNair 831-438-2363 engineer/ manger

Sacramento County Water Agency, Lakeside Water Treatment Plant Filters recoating Project  
Clean and paint interior and Replace Interior Pipe  
Jonathan Eden 916-875-2700 Engineer

In regards to our Georgetown project the filter replacement work is scheduled to be performed by Envirotrol, Jeff Frey (916) 939-7924

Euro Style Management is also a certified for all coatings, linings and Lead Abatement, QP-1, QP-2, Category A contractor

For your review we are attaching our certificates for our company and welders

Thank you,  
Lilia Bugriyev  
Euro Style Management  
3600 Madison Ave # 51B  
North Highlands CA 95660  
916-331-4858



**QUOTATION**

Quote # 20-071

To: ENVIROTROL

Date : 06/24/20

Attention: JEFF FREY

Your Inquiry: MEDIA & GRAVEL

Phone: 916/939-7924

ONE 8X30-4C TANK

Email: JFREY@ENVIROTROLWATER.COM

We are pleased to quote, subject to standard terms and conditions, the following :

1 LOT FILTER MEDIA AND GRAVEL INCLUDING:  
280 CF ANTHRACITE #1  
419 CF (838 BAGS) SAND .45-.55mm F-105 IN 1/2 CF BAGS  
66 CF (132 BAGS) GRAVEL 1/4" x 1/8" IN 1/2 CF BAGS  
64 CF (128 BAGS) GRAVEL 3/4" x 3/8" IN 1/2 CF BAGS  
120 CF (240 BAGS) GRAVEL 3/4" x 1-1/2" IN 1/2 CF BAGS  
NSF MATERIAL SUBMITTAL

LOT PRICE: \$ 21,210.00

FIELD SERVICES AVAILABLE AT \$1,000/DAY PLUS EXPENSES  
NO WARRANTY

Taxable: ADDITIONAL, AS APPLICABLE  
Freight: INCLUDED  
FOB: JOBSITE

Quote Firm: 30 DAYS  
Terms: PER WRT STANDARDS

Shipment can be made : \*\*\* 2 - 3 WEEKS AFTER APPROVAL \*\*\*  
after receipt of your order and complete design information or approval of prints, if required.

***Randy L. Richey***  
Randy L. Richey

Since 1928  
[www.loprest.com](http://www.loprest.com)

2825 Franklin Canyon Rd., Rodeo, CA 94572  
Phone 510-799-3101 - Fax 510-799-7433

1-888-228-5982  
[RRichey@wrtnet.com](mailto:RRichey@wrtnet.com)



Euro Style Management  
*of*  
North Highlands, CA

*has met or exceeded the requirements set forth in the  
SSPC Painting Contractor Certification Program for*

**FIELD APPLICATION OF COATINGS  
COMPLEX STRUCTURES**

**SSPC - QP1**

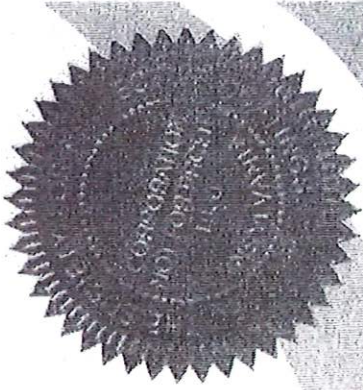

.....  
President, SSPC  
March 31, 2020 – March 31, 2021  
.....  
Validation Period



Certification for dates listed above to Euro Style Mgr. North Highlands, CA  
Owners are advised to contact SSPC at 412.281.2311 ext. 2235 or ext. 2259 to verify authenticity of certification.  
SSPC 800 Trumbull Dr. Pittsburgh, PA 15205 FCCP rules V. July 2019



# Euro Style Management

*of*  
North Highlands, CA

*has met or exceeded the requirements set forth in the  
SSPC Painting Contractor Certification Program for*

## INDUSTRIAL HAZARDOUS PAINT REMOVAL SSPC-QP2

"A"

Category

March 31, 2020 – March 31, 2021

Validation Period

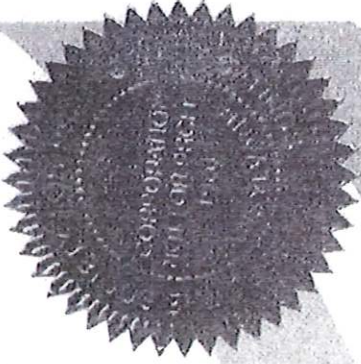

President, SSPC

Certification for dates listed above is Euro Style Mgt. North Highlands, CA  
Owners are advised to contact SSPC at 412-281-2331 ext. 2235 or ext. 2209 to verify authenticity of certification.  
SSPC 880 Trumbull Dr. Pittsburgh, PA 15205. FCCP rules V. July 2019





## Contractor's License Detail for License # 841418

**DISCLAIMER: A license status check provides information taken from the CSLB license database. Before relying on this information, you should be aware of the following limitations.**

- ▶ CSLB complaint disclosure is restricted by law (B&P 7124.6) If this entity is subject to public complaint disclosure click on link that will appear below for more information. Click here for a definition of disclosable actions.
- ▶ Only construction related civil judgments reported to CSLB are disclosed (B&P 7071.17).
- ▶ Arbitrations are not listed unless the contractor fails to comply with the terms.
- ▶ Due to workload, there may be relevant information that has not yet been entered into the board's license database.

Data current as of 6/29/2020 11:54:13 AM

### Business Information

EURO STYLE MANAGEMENT  
 3600 MADISON AVENUE #51-B  
 NORTH HIGHLANDS, CA 95660  
 Business Phone Number:(916) 331-4858

**Entity** Corporation  
**Issue Date** 06/23/2004  
**Expire Date** 06/30/2022

### License Status

This license is current and active.

All information below should be reviewed.

### Classifications

- ▶ C33 - PAINTING AND DECORATING
- ▶ B - GENERAL BUILDING CONTRACTOR
- ▶ A - GENERAL ENGINEERING CONTRACTOR

### Bonding Information

#### Contractor's Bond

This license filed a Contractor's Bond with WESTERN SURETY COMPANY.  
**Bond Number:** 64683992  
**Bond Amount:** \$15,000  
**Effective Date:** 06/27/2019  
 Contractor's Bond History

#### Bond of Qualifying Individual

- ▶ This license filed Bond of Qualifying Individual number **100230066** for STANISLAV ALEXSEEVICH BUGRIYEV in the amount of **\$12,500** with AMERICAN CONTRACTORS INDEMNITY COMPANY.  
**Effective Date:** 08/27/2013  
 BQI's Bond History
- ▶ The qualifying individual VITALIY STANISLAVOVI BUGRIYEV certified that he/she owns 10 percent or more of the voting stock/membership interest of this company; therefore, the Bond of Qualifying Individual is not required.  
**Effective Date:** 01/22/2015  
 BQI's Bond History

### Workers' Compensation

This license has workers compensation insurance with the PREFERRED PROFESSIONAL INSURANCE  
**Policy Number:** ON0944201  
**Effective Date:** 01/27/2020  
**Expire Date:** 01/27/2021  
 Workers' Compensation History



American Welding Society®

**AWS CERTIFIED WELDER**  
Welders, Brazers and Operators

**Anatoly Yefremcnkov**  
Cert # 0703072W

1-800-543-8883 Ext. 273 information relating to identification and certification of the  
bearer of this card may be verified by calling or writing:  
Certification Department of the American Welding Society  
8600 NW 30th St., #130, Miami, FL 33166

Verification of the information on this card, including the test date and expiration date can  
be obtained by visiting the AWS website at [www.aws.org/certification](http://www.aws.org/certification).

THIS CARD IS THE PROPERTY OF AWS AND SHALL BE RETURNED ON DEMAND.



**American Welding Society®**  
**CERTIFIED WELDER**

This card is the property of AWS and shall be returned on demand.

# J B Services

## Welder Qualification Test Record

Page 1 of 1  
 FCAW T8 3&4G 1AY  
 QC1 EXP 8/1/2012

WQTR No. FCAW -T8-3&4G-1AY Welder Name Anatolle Yefremenkov Welder Id: 6301  
 WPS No. FCAWT-8/3&4G/1 Revision \_\_\_\_\_ Date \_\_\_\_\_

<p><b>Variables Record Actual Values Used In Qualification</b></p> <p>Process (Table 4.10, Item (1)) <u>FCAW</u></p> <p>Transfer Mode (GMAW): Short-Cir. <input type="checkbox"/> Globular <input type="checkbox"/> Spray <input type="checkbox"/></p> <p>Type Manual <input type="checkbox"/> Machine <input type="checkbox"/> Semi-Auto <input checked="" type="checkbox"/> Auto <input type="checkbox"/></p> <p>Number of Electrodes Single <input checked="" type="checkbox"/> Multiple <input type="checkbox"/></p> <p>Current/Polarity AC <input type="checkbox"/> DCEP <input type="checkbox"/> DCEN <input checked="" type="checkbox"/> Pulsed <input type="checkbox"/></p> <p>Position (Table 4.10, Item (4)) <u>3&amp;4G</u></p> <p>Weld Progression: (Table 4.10, Item (6)) Up <input checked="" type="checkbox"/> Down <input type="checkbox"/></p> <p>Backing (Table 4.10, Item (7)) Use Backing <input checked="" type="checkbox"/></p> <p>Consumable Insert (GTAW) Use Insert <input type="checkbox"/></p> <p>Material/Spec. <u>A572-50</u> to <u>A572-50</u></p> <p>Thickness (Plate): Groove (in ) <u>1</u></p> <p style="padding-left: 40px;">Fillet ( ) _____</p> <p>Thickness (Pipe/tube): Groove ( ) _____</p> <p style="padding-left: 40px;">Fillet ( ) _____</p> <p>Diameter(Pipe): Groove ( ) _____</p> <p style="padding-left: 40px;">Fillet ( ) _____</p> <p>Notes _____</p> <p>Filler Metal (Table 10, Item (2))</p> <p style="padding-left: 40px;">Spec. <u>A5-20</u></p> <p style="padding-left: 40px;">Class. <u>E71T-8</u></p> <p style="padding-left: 40px;">F-No. <u>6</u></p> <p>Gas/Flux Type (Table 4.10, Item (3)) <u>N/A</u></p> <p>Other _____</p>	<p><b>Qualification Range</b></p> <p><u>FCAW</u></p> <p>Short-Circuiting <input type="checkbox"/> Globular <input type="checkbox"/> Spray <input type="checkbox"/></p> <p>Manual <input type="checkbox"/> Machine <input type="checkbox"/> Semi-Auto <input checked="" type="checkbox"/> Auto <input type="checkbox"/></p> <p>Single <input type="checkbox"/> Multiple <input type="checkbox"/></p> <p>AC <input type="checkbox"/> DCEP <input checked="" type="checkbox"/> DCEN <input type="checkbox"/> Pulsed <input type="checkbox"/></p> <p>All</p> <p>Up <input checked="" type="checkbox"/> Down <input type="checkbox"/></p> <p>With Backing <input checked="" type="checkbox"/> Without Backing <input type="checkbox"/></p> <p>With Insert <input type="checkbox"/> Without Insert <input type="checkbox"/></p> <p><b>Any Approved Table 3.1</b></p> <p><u>1/8</u> - Unlimited in</p> <p><u>1/8</u> - Unlimited in</p> <p><u>1/8</u> - Unlimited in</p> <p><u>1/8</u> - Unlimited in</p> <p><u>&gt;24</u> - Unlimited in</p> <p><u>&gt;24</u> - Unlimited in</p> <p>Qualifies Pipe over 24" Dia.</p> <p>Backgouge req. if backing not used</p> <p>Any A5-20 Electrode</p>
---	---

**VISUAL INSPECTION (4.8.1) Acceptable Yes**

**GUIDED BEND TEST RESULTS (4.30.5)**

Type	Result	Type	Result
3G side bend	Acceptable	3G side bend	Acceptable
4G side bend	Acceptable	4G side bend	Acceptable

**Fillet Test Results (4.30.2.3 and 4.30.4.1)**

Appearance \_\_\_\_\_ Fillet Size \_\_\_\_\_ Macroetch \_\_\_\_\_

Fracture Test Root Penetration \_\_\_\_\_ Description \_\_\_\_\_

Inspected By Jerry Bolln Test No. \_\_\_\_\_ Organization J B Services Date 2/17/2012

**RADIOGRAPHIC TEST RESULTS (4.30.3.1)**

Film Identification No.	Result	Remark

Interpreted By \_\_\_\_\_  
 Organization \_\_\_\_\_  
 Test No. \_\_\_\_\_  
 Date \_\_\_\_\_

We, the undersigned, certify that the statements in this record are correct and that the test welds were prepared, welded, and tested in accordance with the requirements of section 4 of ANSI/AWS D1.1, ( 2010 ) Structural Welding Code-Steel.

Manufacturer J B Services Authorized By Jerry W Bolln Date 2/17/2012

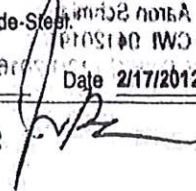
  
 Jerry W Bolln  
 CWI 08080731  
 QC1 EXP. 8/1/2012





Jerry W Bolin  
CWI 09080731  
QC1 EXP. 8/1/2016

8-7-12



Jerry W Bolin  
CWI 09080731  
QC1 EXP. 8/1/2016

2-6-13



Jerry W Bolin  
CWI 09080731  
QC1 EXP. 8/1/2016

8-7-13



Jerry W Bolin  
CWI 09080731  
QC1 EXP. 8/1/2016

2-7-14



Jerry W Bolin  
CWI 09080731  
QC1 EXP. 8/1/2016

8-7-14



Jerry W Bolin  
CWI 09080731  
QC1 EXP. 8/1/2016

2-7-15



Seth D Dineen  
CWI 08100291  
QC1 EXP. 10/1/2016

7-2-15

Shane Jueg 12-09-15

Sims metal management

*[Signature]*

Warner Cast 6/28/2016

A.R.C. Scoreboard

2-6-17



Aaron Schmidt  
CWI 04120191  
QC1 EXP. 12/1/2016

Jerry W Bolin  
CWI 09080731  
QC1 EXP. 8/1/2016

Sims Metal Management

00-3-3  
Mark A Reese 7-20-17



Mark A Reese  
SCWI 11080038  
QC1 EXP. 8/1/2020

ARC 2/14/2018

Robert C Morales 7-12-2018



Robert C Morales  
CWI 04041881  
QC1 EXP. 4/1/2019

Big City Welding

503 516-4562

11-28-18

Big City Welding

5-3-19

Big City Welding

11-1-19 503 516-4562

May first, of 2020

Buro Style Management  
Sacramento 916-416-5498

*[Signature]*

## Structural Welding Certification

### WELDER'S WELDING OPERATOR QUALIFICATION TEST RECORD

(NOTICE: OC-1 stamp required for authenticity of Manufacturing)

Name: Dmitry L. Yakimov  
 ID No.: GDL3494795  
 Date of Test: 5/3/2019

Essential Variables Qualified By:  
 Tests: n/a  
 Prequalified: X

Material Specification Type and Grade:  
ASTM A36, A53, A500, A572, A500 to same

Backing Material: n/a  
 Filler Material: 5/64 NR 232  
 Spec: A530 Class: E7T8  
 Manuf. Name: Lincoln International NR 232

**Qualification Test Performed**

WPS Number: ANSI/AWS REF. D1.1 - 2015  
 Joint: B-U2a-GE B-1/4 @ 45  
 Fillet: N/A  
 Weld Test: Prequalified  
 Braze Weld Test: n/a

Welding Process: TIG  
 Method of Application:  
n/a Manual X Semi auto n/a Automatic  
 Mode of Transfer:  
n/a SS X Globular n/a Spray

Welding Current:  
20-27 Volts 25/43 IPM  
21-26 Volts  
n/a DCEP X DCEN  
 Shield Gas Used: Yes Self Shielded  
 Position Welded: Flat Horizontal  
3G Vertical 4G Overhead  
 Progression: Overhead & Vertical

**Visual Inspection Results:**

	Accept	Reject	Comments
Appearance	X		
Required Joint Penetration	X		
Discontinuities Under an	X		
Other: <u>n/a</u>			

Guided Bend Test Results: <u>n/a</u>			Break Tests: <u>n/a</u>			Other:		
Type	Specimen No. 2	Results	Type	Specimen No. 2	Results	Type	Specimen No. 2	Results
Face	Visual	Yes	Face	Visual	Yes			
Root	Visual	Yes	Root	Visual	Yes			
Side	Bend	Yes	Side	Bend	Yes			

Thickness Range Qualified: 1/8 to Unlimited  
 Position Qualified: EVA  
 Types of Joints Qualified: Plate Groove (CJP) FH  
Plate Flat F.H. Pipe Bar Groove (CJP) FH  
Pipe Flat F.H. Bar Tubing Groove (CJP) FH  
Pipe Tubing Flat FH

Signed By: [Signature]

**RESOLUTION NO. 2020-XX**

**OF THE BOARD OF DIRECTORS OF THE  
GEORGETOWN DIVIDE PUBLIC UTILITY DISTRICT  
AUTHORIZING THE GENERAL MANAGER TO EXECUTE A CONSTRUCTION  
CONTRACT WITH ERS INDUSTRIAL SERVICES, INC. IN THE AMOUNT OF \$54,640  
FOR THE WALTON LAKE WATER TREATMENT PLANT FILTER NO. 3  
REHABILITATION PROJECT AND AUTHORIZING THE GENERAL MANAGER TO  
APPROVE CHANGE ORDERS NOT TO EXCEED 20% OF THE CONTRACT  
AMOUNT.**

**WHEREAS**, the Walton Lake Water Treatment Plant Filter No. 3 Rehabilitation Project is planned for Fiscal Year 2019/20 in the Board Adopted Five Year Capital Improvement Plan; and

**WHEREAS**, a notice inviting bids to select a contractor to perform the Project was issued on June 10, 2020, and two (2) bids were received on July 1, 2020; and

**WHEREAS**, after reviewing bids, District Staff have determined that ERS INDUSTRIAL SERVICES, INC. was the lowest responsive and responsible bidder; and

**WHEREAS**, the ERS INDUSTRIAL SERVICES, INC. Total Bid Price is in the amount of \$54,640.00; and

**WHEREAS**, the project expenditures will be less than the total project budget of \$100,000.

**NOW, THEREFORE, BE IT RESOLVED BY THE BOARD OF DIRECTORS OF THE  
GEORGETOWN DIVIDE PUBLIC UTILITY DISTRICT THAT:**

1. The construction contract is awarded to ERS INDUSTRIAL SERVICES, INC..
2. The General Manager is authorized to execute a construction contract with ERS INDUSTRIAL SERVICES, INC. in the amount of \$54,640.00 for the Project.
3. The General Manager is authorized to approve change orders not to exceed 20% of the contract amount.

**PASSED AND ADOPTED** by the board of Directors of the Georgetown Divide Public Utility District at a meeting of said Board held on the eighth day of September 2020, by the following vote:

AYES:

NOES:

ABSENT/ABSTAIN:

---

David Souza, President, Board of Directors  
GEORGETOWN DIVIDE PUBLIC UTILITY DISTRICT

*Attest:*

---

Jeff Nelson, Clerk and Ex officio  
Secretary, Board of Directors  
GEORGETOWN DIVIDE PUBLIC UTILITY DISTRICT

#### **CERTIFICATION**

I hereby certify that the foregoing is a full, true and correct copy of Resolution 2020-XX duly and regularly adopted by the Board of Directors of the Georgetown Divide Public Utility District, County of El Dorado, State of California, on the 8th day of September, 2020.

---

Jeff Nelson, Clerk and Ex officio  
Secretary, Board of Directors  
GEORGETOWN DIVIDE PUBLIC UTILITY DISTRICT